

REV.	ECN NO OR DESCRIPTION	REVISED	DATE
A	PDR NO:T151209-12A	Edi.Zhou	2018.03.08
B	ECN NO:S180909-C	WENRONG	2018.09.05
C	ECN NO:S190542-E	KIWIMAN	2019.07.11
D	ECN NO:S202108-C07	TAO	2021.08.17
E	ECN NO:S202204-R03	TAO	2022.04.14

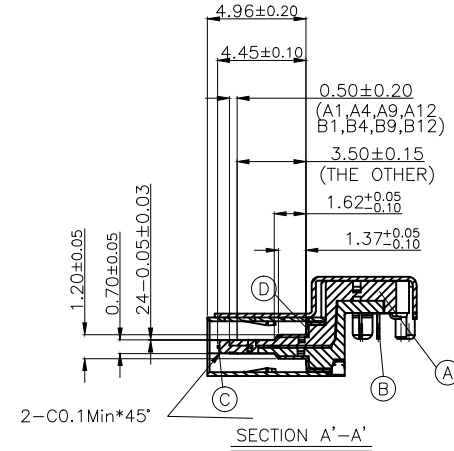

RECOMMENDED P.C.B LAYOUT(TOP VIEW)
TOLERANCE=±0.05(THK:1.6mm)

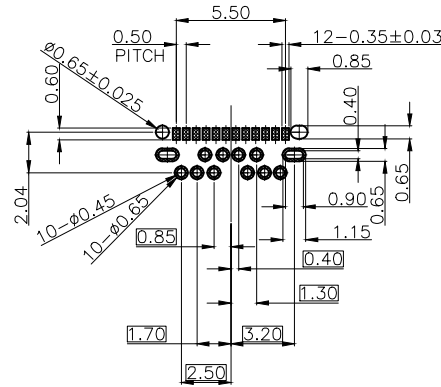
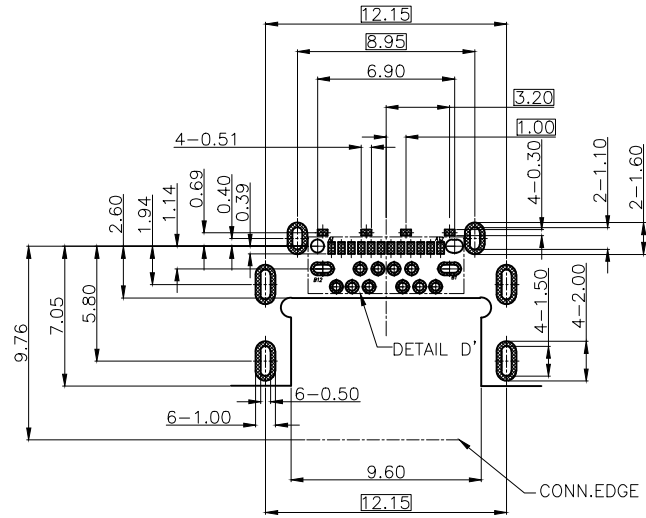
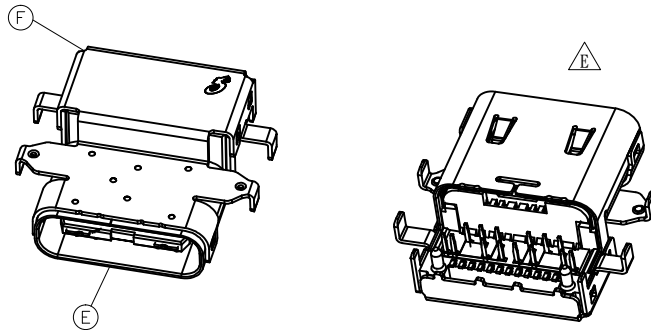

NO.	PIN NUMBER	SIGNAL NAME	NO.	PIN NUMBER	SIGNAL NAME
1	A1	GND	13	B12	GND
2	A2	SSTXp1	14	B11	SSRXp1
3	A3	SSTXn1	15	B10	SSRXn1
4	A4	VBUS	16	B9	VBUS
5	A5	CC1	17	B8	RFU2
6	A6	Dp1	18	B7	Dn2
7	A7	Dn1	19	B6	Dp2
8	A8	RFU1	20	B5	CC2
9	A9	VBUS	21	B4	VBUS
10	A10	SSRXn2	22	B3	SSTXn2
11	A11	SSRXp2	23	B2	SSTXp2
12	A12	GND	24	B1	GND

NO.	DESCRIPTION	QTY	MATERIAL	PLATING & COLOR
UNLESS OTHERWISE SPECIFIED TOLERANCES		Singatron Enterprise Co., Ltd. 信音企業股份有限公司		
DECIMALS: ANGLES:		TITLE: USB TYPE -C MID-MOUNT(C.H.=-1.40)		
X :±0.5	X :±2°	DWN TAO	PART NO: 2UB3C02-002111F	
X.X :±0.3	X.X :±1°	CHKD boye	SCALE:4:1	UNIT: mm
X.XX :±0.2		APVD LIAO	SIZE: A3	SHEET:2 OF 2
REV:E				
CUSTOMER COPY				