

REV.	ECN NO.	OR DESCRIPTION	REVISED	DATE
A	PDR	RELEASE	EVEN	2017.06.22
B	ECN NO.:	L201909-C04/C05	IV-C	2019.12.02
C	ECN NO.:	L202005-002	IV-C	2020.06.22

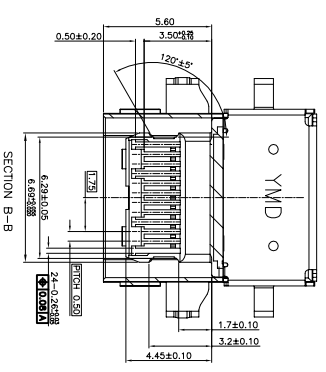
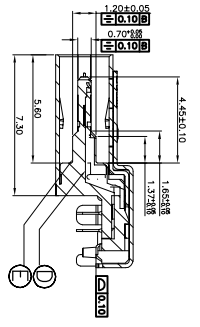
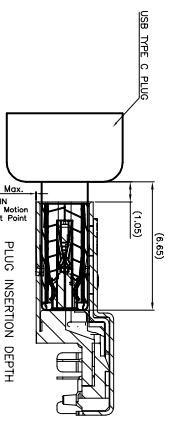
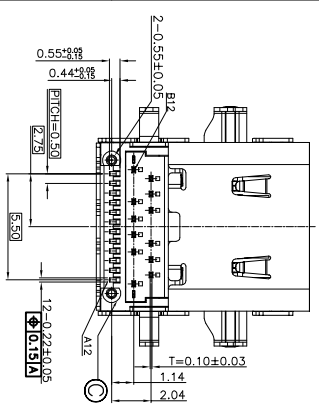
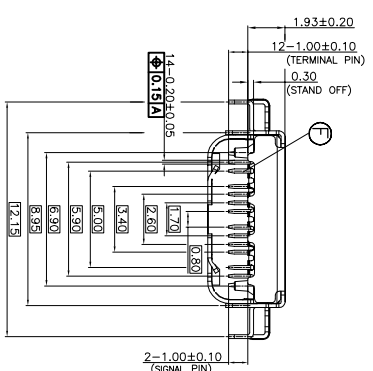
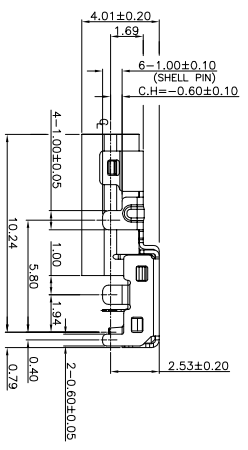
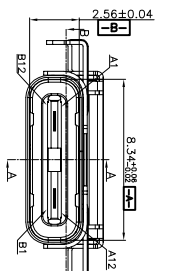
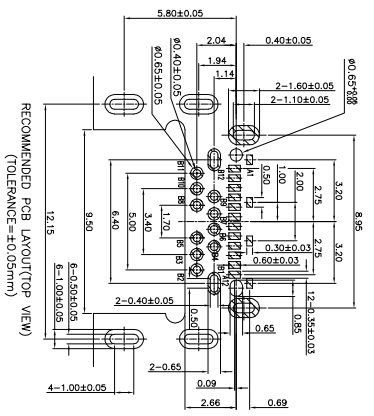
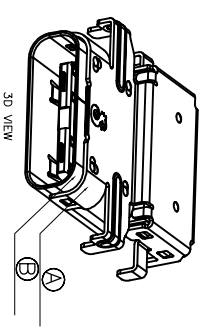
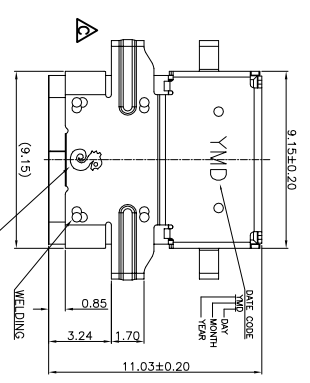

USB TYPE-C PIN ASSIGNMENTS.			
A12	GND	B1	GND
A11	SSRX2	B2	SSTX2
A10	SSRX2	B3	SSTX2
A9	VBUS	B4	VBUS
A8	SBUS1	B5	CC2
A7	Dn1	B6	Dp2
A6	Dn1	B7	Dn2
A5	CC1	B8	SBUS2
A4	VBUS	B9	VBUS
A3	SSTX1	B10	SSRX1
A2	SSTX1	B11	SSRX1
A1	GND	B12	GND

TERMINAL	DESCRIPTION	ANGLE:	DECIMALS:
F	TERMINAL		
E	RFL PAD		
D	SIGNAL		
C	HOUSING		
B	INNER SHELL		
A	OUTSIDE SHELL		
NO	DESCRIPTION		

- SPECIFICATIONS:**
- ELECTRICAL CHARACTERISTICS:
    - CURRENT RATING: 5.0A
    - VOLTAGE RATING: 5.0 V
    - LCR: VBUS& GND PINS: 40mΩ/PIN MAX
  - MECHANICAL CHARACTERISTICS:
    - INSULATION RESISTANCE: 100MΩ MIN
    - INSERTION FORCE: 0.5~2.0kg
    - WITHDRAWAL FORCE: 1.4~2.0kg (INITIAL: 30/CYCLES) 0.6~2.0kg (AFTER LIFE TEST)
  - DURABILITY: 10,000 CYCLES.
  - TO CONFORM TO THE SINGATRON HAZARDOUS SUBSTANCE FREE SPEC.
  - HALOGEN FREE PRODUCT IDENTIFICATION LABEL ON PACKAGING.
  - PACKAGE: SEE "2UB3C02-100211F" PACKAGE.
  - FOR REFLOW SOLDERING LEAD-FREE PROCESS.
  - OTHER GENERAL SPEC. TO REFER "2UB3C02-100211F SPEC."

**PART NO.**  
2UB3C02-100211F

SUFFIX: HALOGEN FREE

1: CH=-0.60mm

PACKAGE: HALOGEN FREE  
1: TAPE & REEL  
HOUSING COLOR: BLACK  
CONTACT PLATING: 2: 50u" AU ON MATING AREA, MATTIE Sn 60~150u" ON SOLDERING AREA, 50u" MIN NICKEL UNDER PLATING OVERALL

Singatron Enterprise Co., Ltd.  
信登企業股份有限公司

TITLE: USB TYPE C, Mid-mount(CH=-0.60mm)

DWN: W-C 2020.06.22 PART NO. 2UB3C02-100211F

CHKD: ANGEL 2020.06.22 SCALE 1:1 UNIT: mm

APVD: ANGEL 2020.06.22 SIZE: A3 SHEET: 1 OF 1 REV: C

CUSTOMER COPY