

REV.	ECN NO OR DESCRIPTION	REVISED	DATE
A	PDR RELEASE	Even	2020.04.28

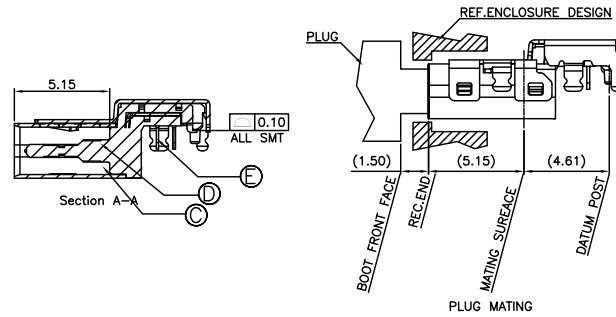

SPECIFICATIONS:

- ELECTRICAL CHARACTERISTICS:
  - CURRENT RATING: 5.0A
  - VOLTAGE RATING: 20.0 V
  - LLCR: VBUS & GND PINS: 40mΩ/PIN MAX  
OTHER PINS : 40mΩ/PIN MAX  
LLCR MAX. CHANGE OF ALL PINS: 10mΩ
- MECHANICAL CHARACTERISTICS:
  - INSERTION FORCE: 0.5~2.0kg.
  - WITHDRAWAL FORCE: 0.8~2.0kg.(INITIAL) 0.6~2.0kg.(AFTER LIFE TEST)
- DURABILITY: 10,000 CYCLES.
- TO CONFORM TO THE SINGATRON HAZARDOUS SUBSTANCE FREE SPEC.
- HALOGEN FREE PRODUCT IDENTIFICATION LABEL ON PACKAGING:
- PACKAGE: SEE "2UB3C02-510111F" PACKAGE.
- FOR REFLOW SOLDERING LEAD-FREE PROCESS.
- OTHER GENERAL SPEC. TO REFER "2UB3C02-510111F SPEC".

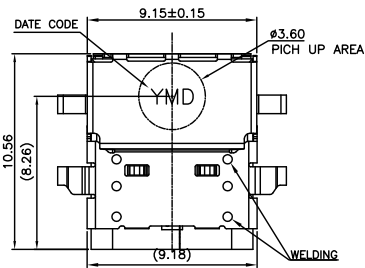
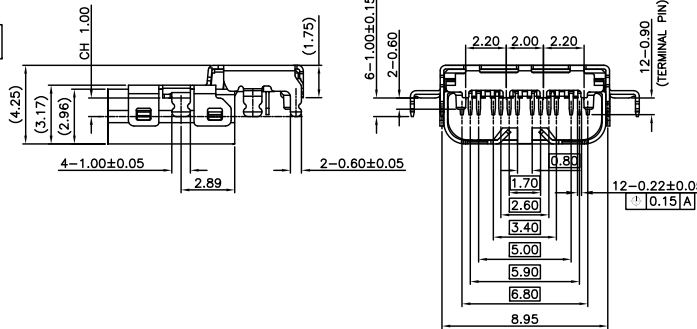
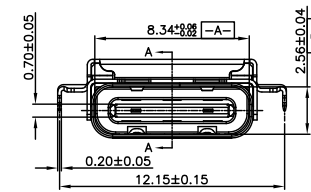

PART NO.  
2UB3C02-510111F

- SUFFIX: HALOGEN FREE
- PACKAGE: 1: TAPE & REEL
- HOUSING COLOR: 1: BLACK
- CONTACT PLATING: 1: 30uAu PLATING ON MATING AREA, MATTE Sn 60u" MIN. ON SOLDERING AREA, 50u" MIN. NICKEL UNDER PLATING OVERALL

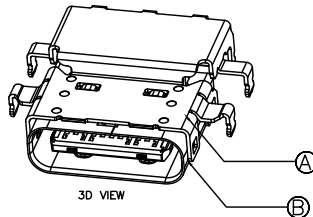
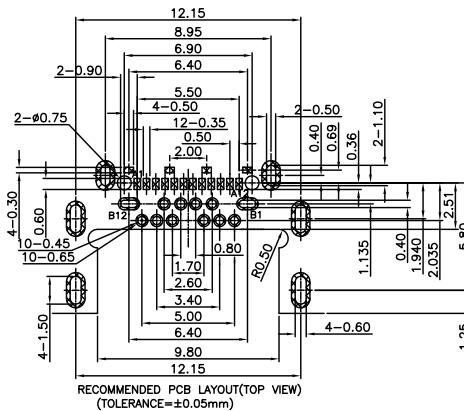
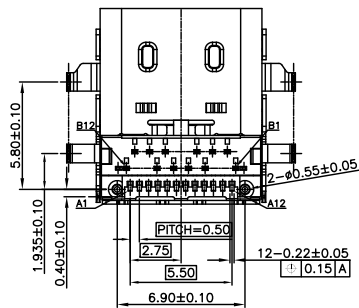

NO	DESCRIPTION	QTY	MATERIAL	PLATING & COLOR
E	TERMINAL	24	C19400R-H	SEE PART NO.
D	SIGNAL	1	SUS 301	NICKEL PLATED 50u"MIN.
C	HOUSING	1	PA9T UL 94V-0	BLACK
B	INNER SHELL	1	SUS 301	NICKEL PLATED 50u"MIN.
A	OUTSIDE SHELL	1	SUS 301	NICKEL PLATED 50u"MIN.

UNLESS OTHERWISE SPECIFIED TOLERANCES		SINGATRON ENTERPRISE CO., LTD. 信音企業股份有限公司	
DECIMALS:	ANGLES:	TITLE	USB TYPE C, Mid-mount(CH=-1.00mm)
X :±0.5	X :±2°	DWN	EVEN 2020.04.28 PART NO. 2UB3C02-510111F
X.X :±0.3	X.X :±1°	CHKD	SCALE 1:1 UNIT: mm
X.XX :±0.2		APVD	ANGELA2020.04.28 SIZE: A3 SHEET:1 OF 1 REV:A

CUSTOMER COPY