

3D VIEW

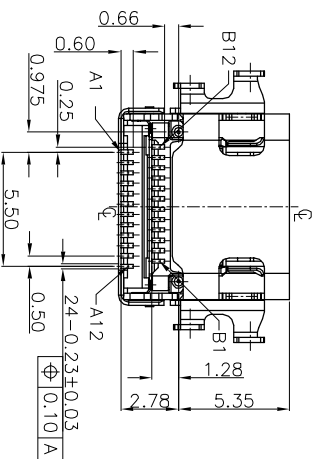
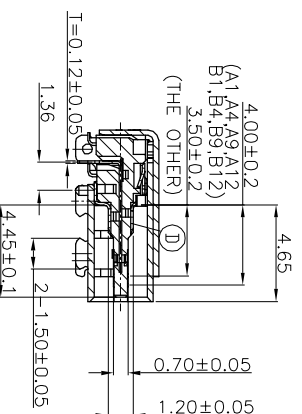
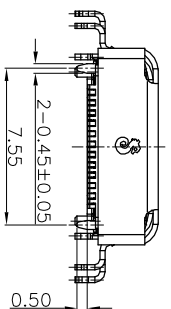
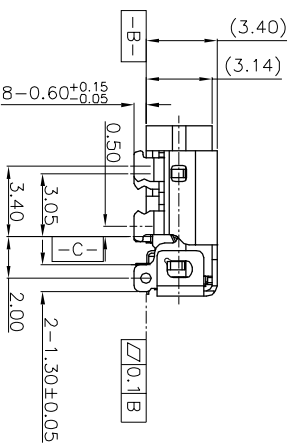
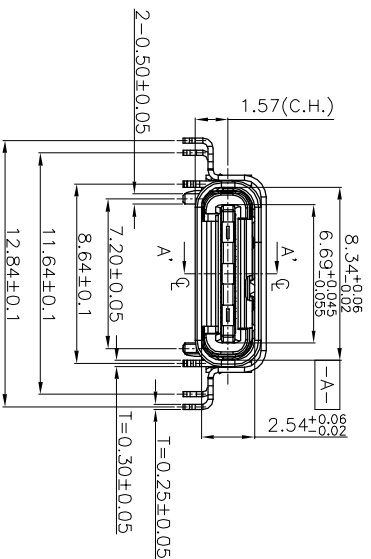

SPECIFICATIONS:

1. ELECTRICAL CHARACTERISTICS:
 - 1-1. LCCR:
 - VBUS & GND PINS&OTHER PINS: 40mΩ MAX
 - AFTER ENVIRONMENT TEST: 50mΩ MAX.
 - 1-2. CURRENT RATING: 3.0 A Max.
 - 1-3. VOLTAGE RATING: 5.0 V.
 - 1-4. INSULATION RESISTANCE: 100MΩ MIN.
- 1-5. ENVIRONMENTAL PERFORMANCE:
 - OPERATING TEMPERATURE: -55°C~+85°C.
2. MECHANICAL CHARACTERISTICS:
 - 2-1. MATING FORCE : 0.5~2.0 kgf.
 - 2-2. UNMATING FORCE : 0.8-2.0 kgf.(1~1000CYCLES),0.6-2.0 kgf.(AFTER 1000 CYCLES)
3. LIFE TEST: 10000 CYCLES MIN.
4. TO CONFORM TO SINGATRON HAZARDOUS SUBSTANCE FREE SPEC.
5. HALOGEN FREE PRODUCT IDENTIFICATION MARK ON JACK:
6. HALOGEN FREE PRODUCT IDENTIFICATION LABEL ON PACKAGING:
7. FOR REFLOW SOLDERING LEAD-FREE PROCESS.

F	TOP SHELL	1	SUS304-1/2H,T=0.25	NICKEL 50U *MIN
E	SHELL	1	SUS304-1/2H,T=0.30	NICKEL 50U *MIN
D	MATE GROUND	1	SUS304-1/2H,T=0.12	N/A
C	MID GROUND	1	SUS301-EH	NICKEL 50U *MIN
B	CONTACT	24	C7035,T=0.12	As Sup. 800uIn PVD PLATED ON CONTACT AREA Matl. Sn 100uIn Min. PLATED ON SOLDERING 50uIn NICKEL UNDER PLATING OVERALL
A	BODY	1	LCP 6808U UL94-V0	BLACK
NO	DESCRIPTION		MATERIAL	PLATING & COLOR

UNLESS OTHERWISE SPECIFIED TOLERANCES



Singatron Enterprise Co., Ltd.
信營企業股份有限公司

DECIMALS:	ANGLES:			
X : ±0.5	X : ±2°			
X.X : ±0.3	X.X : ±1°			
X.XX : ±0.2				
TITLE	USB TYPE -C ON BOARD SMT REC(C.H.=1.57)			
DWN	Edi.Zhou	PART NO: 2UB3C08-000111F		
CHKD	Boye	SCALE:4:1	UNIT: mm	
APVD	Boye	SIZE: A3	SHEET: 1 OF 2	REV: A

CUSTOMER COPY

REV.	ECN NO OR DESCRIPTION	REVISED	DATE
A	PDR NO.:T161026-3A	Edi.Zhou	2018.03.09

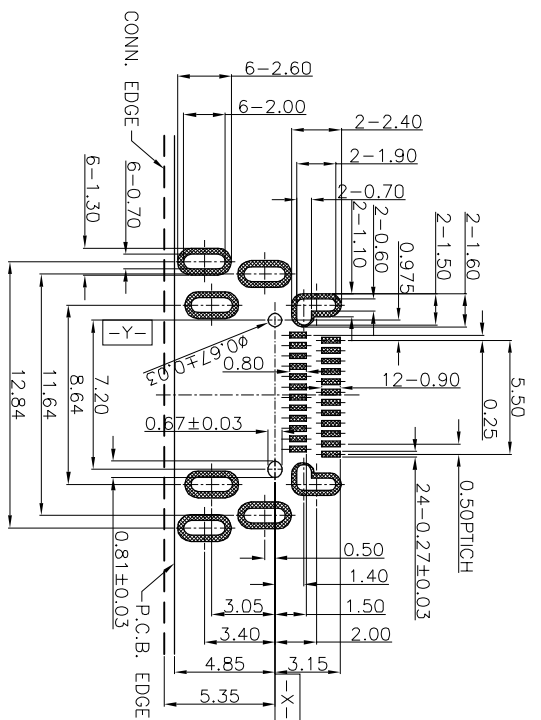

RECOMMENDED P.C.B. LAYOUT(TOP VIEW)
TOLERANCE=±0.05(THK:0.8mm)

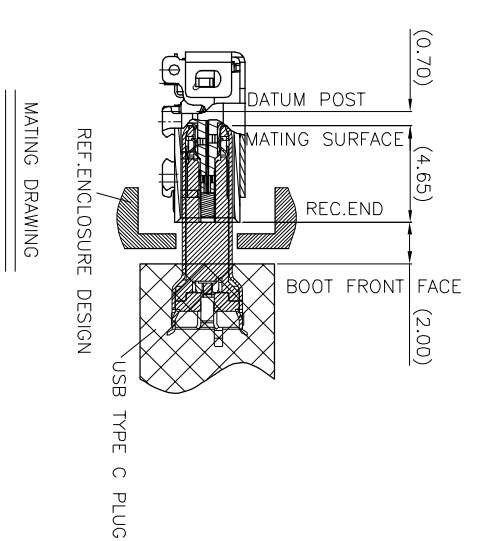

NO	DESCRIPTION	QTY	MATERIAL	PLATING & COLOR
1	NO1 PIN NUMBER			
2	A1			
3	A2			
4	A3			
5	A4			
6	A5			
7	A6			
8	A7			
9	A8			
10	A9			
11	A10			
12	A11			
13	A12			

UNLESS OTHERWISE SPECIFIED TOLERANCES

DECIMALS:	ANGLES:
X :±0.5	X :±2°
X.X :±0.3	X.X :±1°
X.XX :±0.2	

TITLE	USB TYPE -C ON BOARD SMT REC(C.H.=1.57)
DWN	Edi.Zhou
CHKD	Boye
APVD	Boye
PART NO.	2UB3C08-000111F
SCALE	4:1
UNIT	mm
SIZE	A3
SHEET	2 OF 2
REV	A

Singatron Enterprise Co., Ltd.
信登企業股份有限公司
CUSTOMER COPY

