

PIN ASSIGNMENT(Front)											
A1	A2	A3	A4	A5	A6	A7	A8	A9	A10	A11	A12
GND	TX1+	TX1-	Vbus	CC1	D-	D+	CC2	Vbus	RX2-	RX2+	GND
GND	RX1+	RX1-	Vbus	SBU2	D-	D+	CC2	Vbus	TX2-	TX2+	GND
B12	B11	B10	B9	B8	B7	B6	B5	B4	B3	B2	B1

REV.	ECN NO OR DESCRIPTION	REVISED	DATE
A	PDR NO.:T191007-3A	TAO	2021.07.19

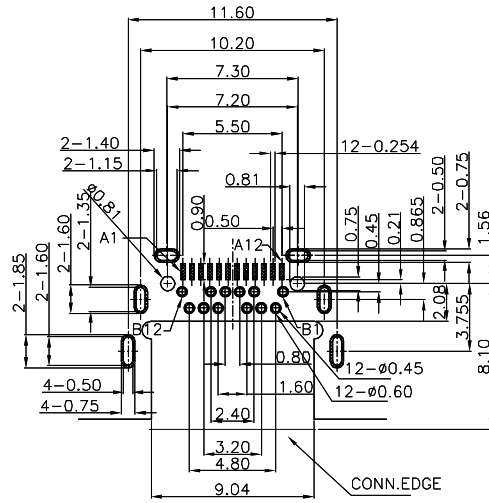

RECOMMENDED P.C.B LAYOUT(TOP VIEW)  
TOLERANCE=±0.05(THK:1.00mm)

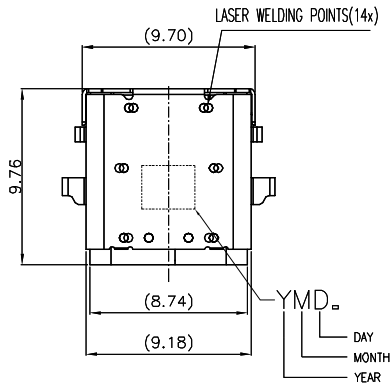
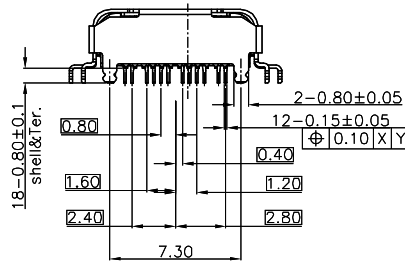
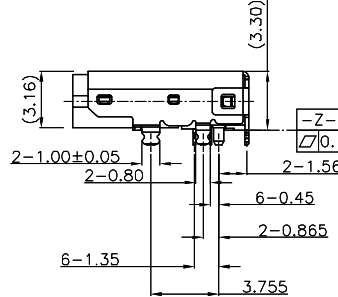

SPECIFICATIONS:

1. ELECTRICAL CHARACTERISTICS:

- 1-1. LLCR:  
VBUS & GND PINS: 40mΩ /PIN Max.  
OTHER PINS: 40mΩ /PIN Max.  
LLCR Max. CHANGE OF ALL PINS: 10mΩ
- 1-2. CURRENT RATING: 3.0 A Max.
- 1-3. VOLTAGE RATING: 5.0 V.
- 1-4. INSULATION RESISTANCE: 100MΩ Min.
- 1-5. ENVIRONMENTAL PERFORMANCE:  
OPERATING TEMPERATURE: -55°C+85°C.

2. MECHANICAL CHARACTERISTICS:

- 2-1. MATING FORCE : 0.5-2.0 Kgf.
- 2-2. UNMATING FORCE : 1.4 Kgf Min. After test 0.6~2.0Kgf.
- 3. LIFE TEST: 10000 CYCLES Min.

4. TO CONFORM TO SINGATRON HAZARDOUS SUBSTANCE FREE SPEC.

- 5. HALOGEN FREE PRODUCT IDENTIFICATION MARK ON JACK:
- 6. HALOGEN FREE PRODUCT IDENTIFICATION LABEL ON PACKAGING:
- 7. FOR REFLOW SOLDERING LEAD-FREE PROCESS.

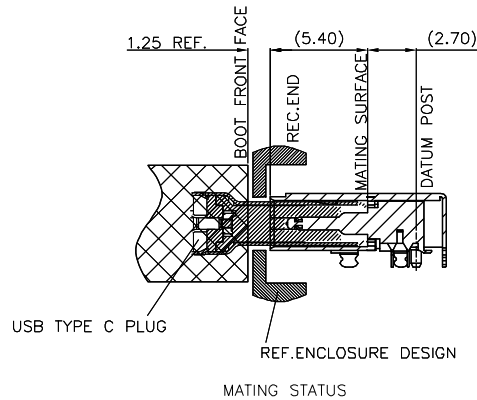
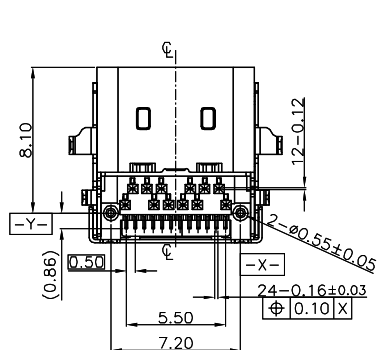
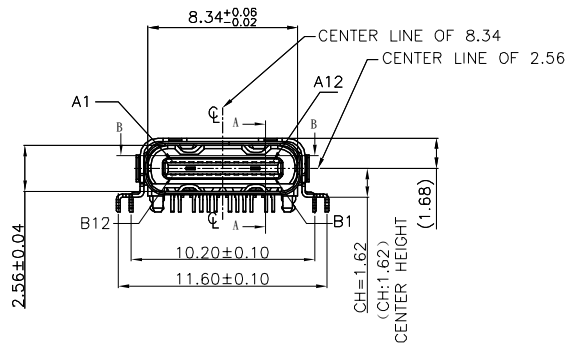

NO	DESCRIPTION	QTY	MATERIAL	PLATING & COLOR
E	TOP SHELL	1	STAINLESS STEEL,T=0.20mm	60µin Min. SOLDERABLE NICKEL PLATING
D	SHELL	1	STAINLESS STEEL,T=0.20mm	N/A
C	MID-GND	1	STAINLESS STEEL,T=0.15mm	N/A
B	CONTACT	24	COPPER ALLOY,T=0.12mm	30µin Min. Au PLATING ON CONTACT AREA; 100µin Min. Matt. Tin PLATING ON SOLDER TAIL AREA AND 80µin Min. NICKEL UNDER PLATING.
A	BODY	1	HIGH TEMP THERMOPLASTIC	BLACK

UNLESS OTHERWISE SPECIFIED TOLERANCES		Singatron Enterprise Co., Ltd. 信音企業股份有限公司	
DECIMALS:	ANGLES:	TITLE	USB TYPE -C R/A HYBRID TYPE (C.H.=1.62)
X : ±0.5	X : ±2°	DWN TAO	PART NO: 2UB3C35-000111F
X.X : ±0.3	X.X : ±1°	CHKD	SCALE:4:1 UNIT: mm
X.XX : ±0.2		APVD	SIZE: A3 SHEET:1 OF 2 REV:A
<b>CUSTOMER COPY</b>			

REV.	ECN NO OR DESCRIPTION	REVISED	DATE
A	PDR NO.:T191007-3A	TAO	2021.07.20

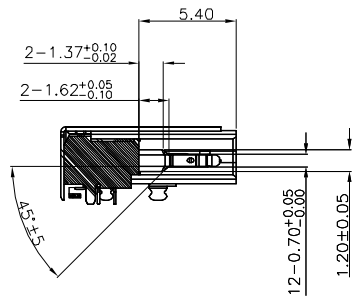

SECTION A-A

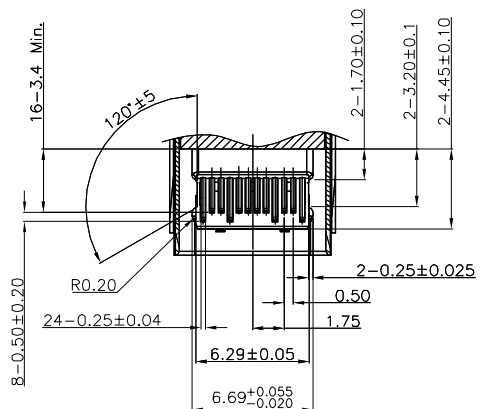

SECTION B-B

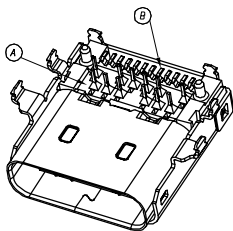
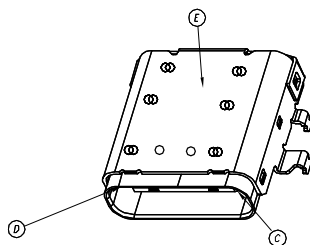

3D VIEW

NO	DESCRIPTION	QTY	MATERIAL	PLATING & COLOR
UNLESS OTHERWISE SPECIFIED TOLERANCES		 Singatron Enterprise Co., Ltd. 信音企業股份有限公司		
DECIMALS: ANGLES:		TITLE: USB TYPE -C R/A HYBRID TYPE (C.H.=1.62)		
X	:±0.5	X	:±2°	DWN TAO PART NO: 2UB3C35-000111F
X.X	:±0.3	X.X	:±1°	CHKD BOYE SCALE:4:1 UNIT: mm
X.XX	:±0.2	APVD LIAO SIZE: A3 SHEET:2 OF 2		REV:A
CUSTOMER COPY				