

PIN ASSIGNMENT(Front)											
A1	A2	A3	A4	A5	A6	A7	A8	A9	A10	A11	A12
GND	TX1+	TX1-	Vbus	CC1	D+	D-	SBU1	Vbus	RX2-	RX2+	GND
GND	RX1+	RX1-	Vbus	SBU2	D-	D+	CC2	Vbus	TX2-	TX2+	GND
B12	B11	B10	B9	B8	B7	B6	B5	B4	B3	B2	B1

REV.	ECN NO OR DESCRIPTION	REVISED	DATE
A	PDR NO.:T200714-5A	TAO	2021.08.13

SPECIFICATIONS:

1. ELECTRICAL CHARACTERISTICS:

- 1-1. LLCR:  
VBUS & GND PINS: 40mΩ /PIN Max.  
OTHER PINS: 40mΩ /PIN Max.  
LLCR Max. CHANGE OF ALL PINS: 10mΩ
- 1-2. CURRENT RATING: 3.0 A Max.
- 1-3. VOLTAGE RATING: 5.0 V.
- 1-4. INSULATION RESISTANCE: 100MΩ Min.
- 1-5. ENVIRONMENTAL PERFORMANCE:  
OPERATING TEMPERATURE: -55°C~+85°C.

2. MECHANICAL CHARACTERISTICS:

- 2-1. MATING FORCE : 5N~20N.
- 2-2. UNMATING FORCE : 14N Min. AFTER TEST 6N~20N
- 3. LIFE TEST: 10000 CYCLES Min.
- 4. TO CONFORM TO SINGATRON HAZARDOUS SUBSTANCE FREE SPEC.
- 5. HALOGEN FREE PRODUCT IDENTIFICATION MARK ON JACK:
- 6. HALOGEN FREE PRODUCT IDENTIFICATION LABEL ON PACKAGING:
- 7. FOR REFLOW SOLDERING LEAD-FREE PROCESS.

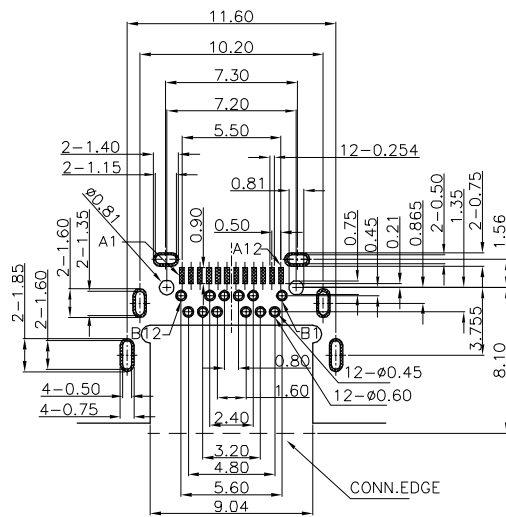
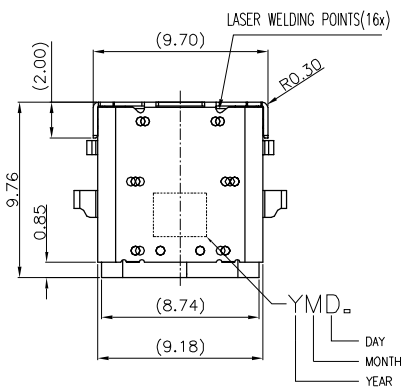

RECOMMENDED P.C.B LAYOUT(TOP VIEW)  
TOLERANCE=±0.05(THK: 1.00mm)

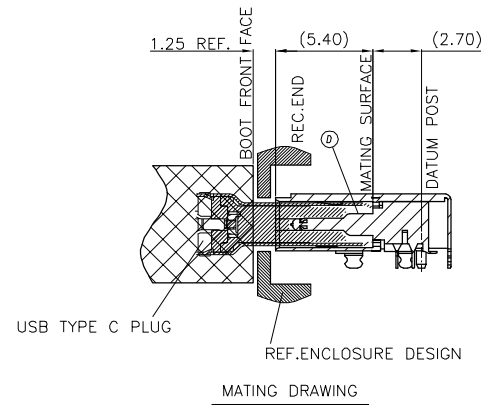
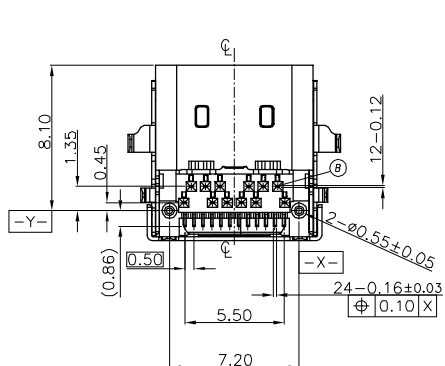
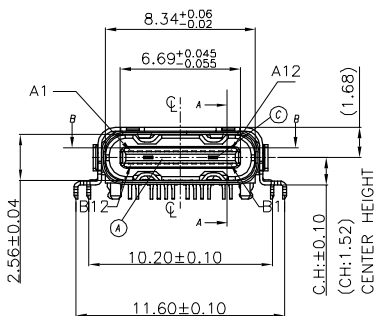
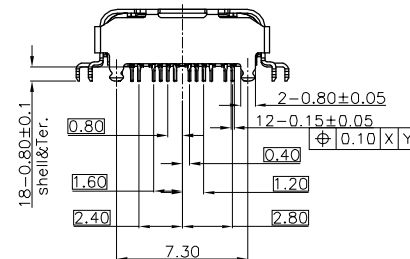
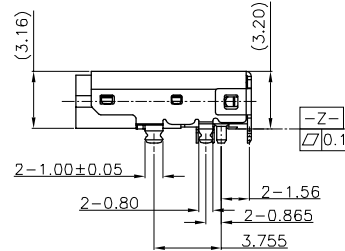

NO	DESCRIPTION	QTY	MATERIAL	PLATING & COLOR
E	TOP SHELL	1	STAINLESS STEEL,T=0.20	80µin Min. SOLDERABLE NICKEL PLATING.
D	SHELL	1	STAINLESS STEEL,T=0.20	N/A
C	MID-GND	1	SUS301 T=0.15	N/A
B	CONTACT	24	C7025-TM03,T=0.12	30µin. Min. Au PLATING ON CONTACT AREA; 100µin Min. Matt. Tin PLATING ON SOLDER TAIL AREA AND 80µin Min. NICKEL UNDER PLATING.
A	BODY	1	LCP 6808U UL94V-0	BLACK

UNLESS OTHERWISE SPECIFIED TOLERANCES	Singatron Enterprise Co., Ltd. 信音企業股份有限公司			
DECIMALS:	ANGLES:	TITLE	USB TYPE -C R/A HYBRID TYPE (C.H.=1.52)	
X : ±0.5	X : ±2°	DWN TAO	PART NO: 2UB3C35-003111F	
X.X : ±0.3	X.X : ±1°	CHKD BOYE	SCALE:4:1	UNIT: mm
X.XX : ±0.2		APVD LIAO	SIZE: A3	SHEET:1 OF 2
CUSTOMER COPY				

REV.	ECN NO OR DESCRIPTION	REVISED	DATE
A	PDR NO.:T200714-5A	TAO	2021.08.13

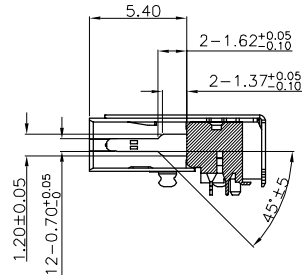

SECTION A-A

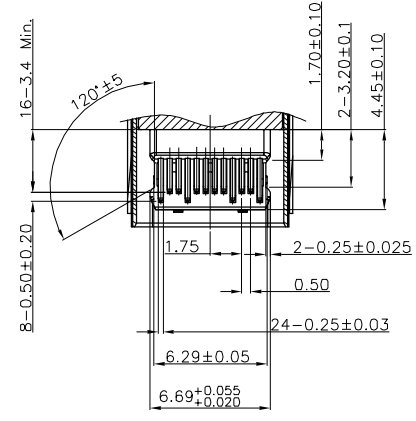

SECTION B-B

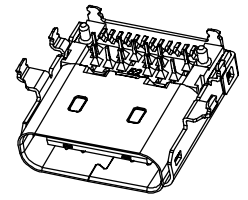
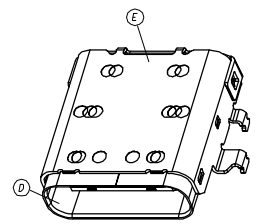

3D VIEW

NO	DESCRIPTION	QTY	MATERIAL	PLATING & COLOR
UNLESS OTHERWISE SPECIFIED TOLERANCES		 Singatron Enterprise Co., Ltd. 信音企業股份有限公司		
DECIMALS:	ANGLES:	TITLE	USB TYPE -C R/A HYBRID TYPE (C.H.=1.52)	
X :±0.5	X :±2°	DWN TAO	PART NO: 2UB3C35-003111F	
X.X :±0.3	X.X :±1°	CHKD BOYE	SCALE:4:1	UNIT: mm
X.XX :±0.2		APVD LIAO	SIZE: A3	SHEET:2 OF 2
CUSTOMER COPY				