





PIN ASSIGNMENT(Front)																							
A2	A3	A4	A5	A6	A7	A8	A9	A10	A11	A12	B12	B11	B10	B9	B8	B7	B6	B5	B4	B3	B2	B1	
GND	TX1+	TX1-	Vbus	CC1	D+	D-	SBU1	Vbus	RX2-	RX2+	GND	GND	RX1+	RX1-	Vbus	SBU2	D-	D+	CC2	Vbus	TX2-	TX2+	GND

REV.	ECN NO OR DESCRIPTION	REVISED	DATE
A	PDR NO.:T210617-5A	chenlong	2021.09.16
B	ECN NO.:S202112-C16	LIRUI	2021.12.28

SPECIFICATIONS:

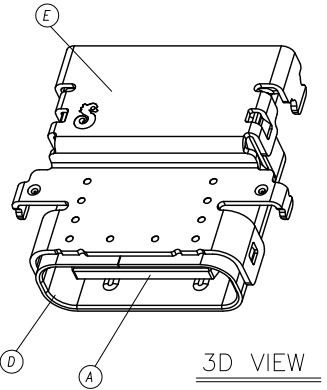
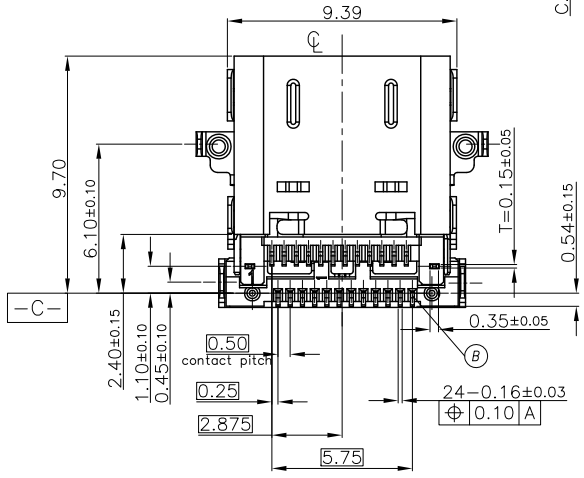
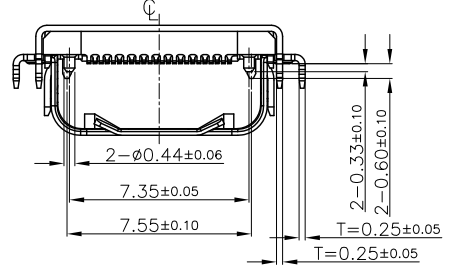
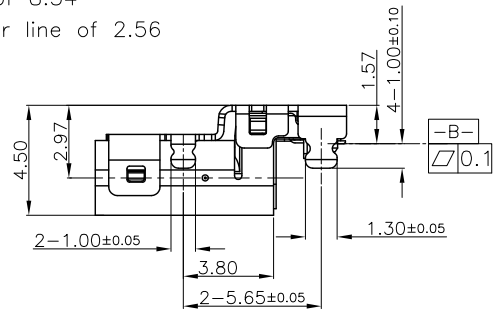
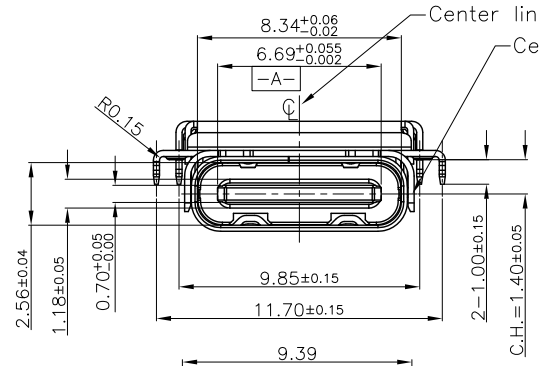
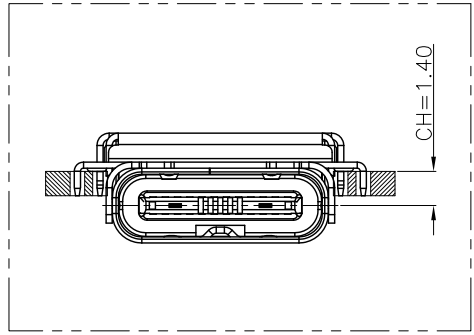
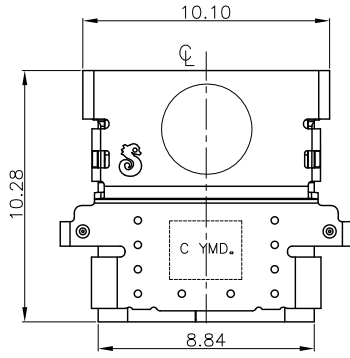
- ELECTRICAL CHARACTERISTICS:
 - LLCR:
 - VBUS & GND PINS: 40mΩ /PIN Max.
 - OTHER PINS: 40mΩ /PIN Max.
 - LLCR MAX. CHANGE OF ALL PINS: 10mΩ.
 - CURRENT RATING: 3.0 A Max.
 - VOLTAGE RATING: 5.0 V.
 - INSULATION RESISTANCE: 100MΩ Min.
 - ENVIRONMENTAL PERFORMANCE:
 - OPERATING TEMPERATURE: -55°C~+85°C.
- MECHANICAL CHARACTERISTICS:
 - MATING FORCE : 0.5~2.0 Kgf.
 - UNMATING FORCE : 0.8~2.0Kgf. After test 0.6Kgf Min.
- LIFE TEST: 10000 CYCLES Min.
- TO CONFORM TO SINGATRON HAZARDOUS SUBSTANCE FREE SPEC.
- HALOGEN FREE PRODUCT IDENTIFICATION MARK ON JACK: 
- HALOGEN FREE PRODUCT IDENTIFICATION LABEL ON PACKAGING: 
- FOR REFLOW SOLDERING LEAD-FREE PROCESS.
- MEET USB TYPE C STANDARD SPECIFICATION, MEET HIGH FREQUENCY STANDARD SPECIFICATION TBT4.



NO	DESCRIPTION	QTY	MATERIAL	PLATING & COLOR
E	TOP SHELL	1	STAINLESS STEEL,T=0.25	80uin Min. Solderable Nickel plating
D	SHELL	1	STAINLESS STEEL,T=0.25	80uin Min. Solderable Nickel plating
C	MID-GND	1	SUS301 T=0.15	80uin Min. Solderable Nickel plating
B	CONTACT	24	C64775-H,T=0.12	G/F plating on contact area,100uin Matte, Tin plating on solder tail area, and 80uin Min Nickel under plating .
A	BODY	1	LCP 6808U UL94-V0	BLACK
UNLESS OTHERWISE SPECIFIED TOLERANCES		 Singatron Enterprise Co., Ltd. 信音企業股份有限公司		
DECIMALS: ANGLES:		TITLE: USB TYPE -C Dual SMT (C.H.=-1.40) TBT4		
X :±0.5	X :±2°	DWN	LIRUI	PART NO: 2UB3C40-000211F
X.X :±0.3	X.X :±1°	CHKD	Allen	SCALE:4:1 UNIT: mm
X.XX :±0.2		APVD	BOYE	SIZE: A3 SHEET:1 OF 2 REV:B
CUSTOMER COPY				

PIN ASSIGNMENT(Front)																							
A1	A2	A3	A4	A5	A6	A7	A8	A9	A10	A11	A12	B12	B11	B10	B9	B8	B7	B6	B5	B4	B3	B2	B1
GND	TX1+	TX1-	Vbus	CC1	D+	D-	SBU1	Vbus	RX2-	RX2+	GND	GND	RX1+	RX1-	Vbus	SBU2	D-	D+	CC2	Vbus	TX2-	TX2+	GND

REV.	ECN NO OR DESCRIPTION	REVISED	DATE
A	PDR NO.:T210617-5A	chenlong	2021.09.16
B	ECN NO.:S202112-C16	LIRUI	2021.12.28

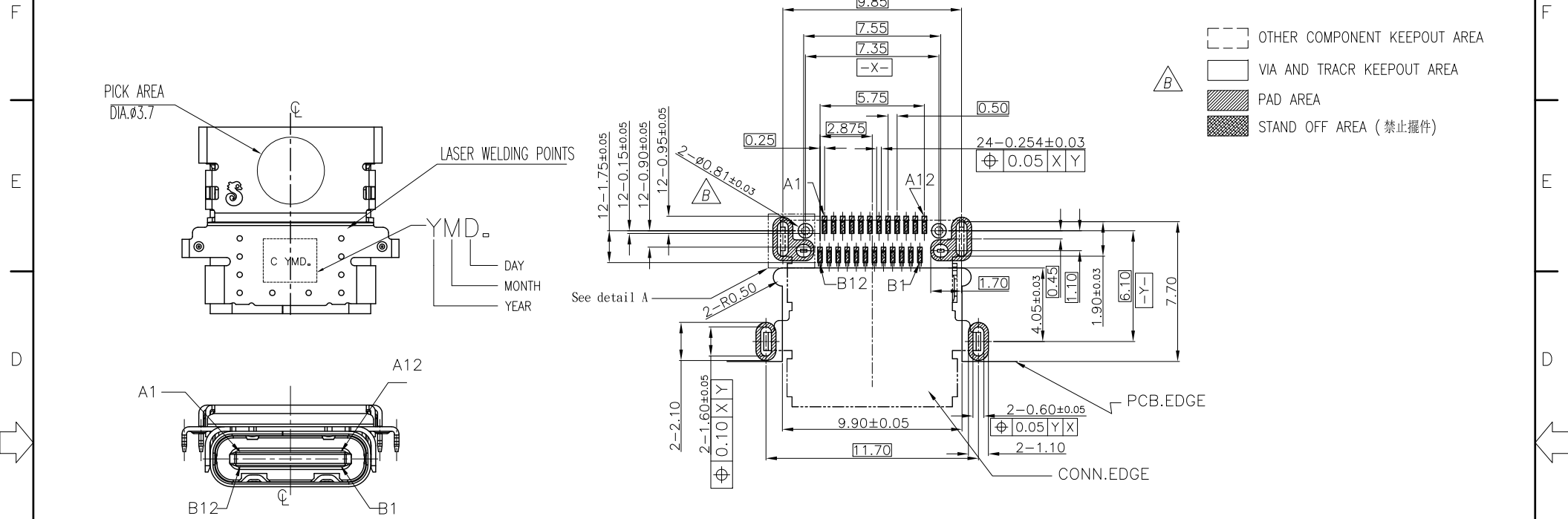

RECOMMENDED P.C.B LAYOUT(TOP VIEW)
TOLERANCE = ± 0.05 (THK: 1.00mm)

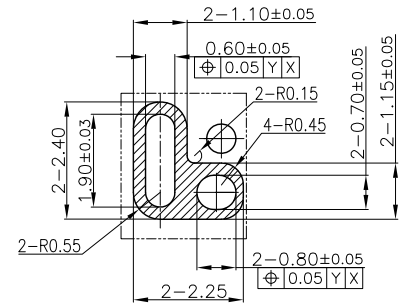
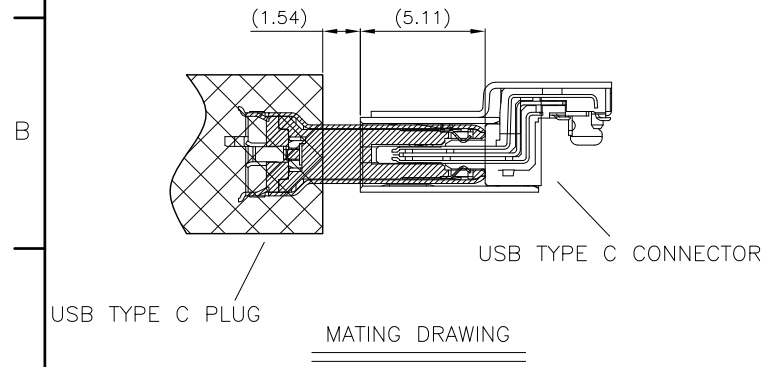

Detail A
Scale 2:1

NO	DESCRIPTION	QTY	MATERIAL	PLATING & COLOR
UNLESS OTHERWISE SPECIFIED TOLERANCES		Singatron Enterprise Co., Ltd. 信音企業股份有限公司		
DECIMALS:	ANGLES:	TITLE	USB TYPE -C Dual SMT (C.H.= -1.40) TBT4	
X : ± 0.5	X : $\pm 2^\circ$	DWN	LIRUI	PART NO: 2UB3C40-000211F
X.X : ± 0.3	X.X : $\pm 1^\circ$	CHKD	Allen	SCALE: 4:1 UNIT: mm
X.XX : ± 0.2		APVD	BOYE	SIZE: A3 SHEET: 2 OF 2 REV: B
CUSTOMER COPY				