

PIN ASSIGNMENT(Front)																							
A2	A3	A4	A5	A6	A7	A8	A9	A10	A11	A12	B12	B11	B10	B9	B8	B7	B6	B5	B4	B3	B2	B1	
GND	TX1+	TX1-	Vbus	CC1	D+	D-	SBU1	Vbus	RX2-	RX2+	GND	GND	RX1+	RX1-	Vbus	SBU2	D-	D+	CC2	Vbus	TX2-	TX2+	GND

REV.	ECN NO OR DESCRIPTION	REVISED	DATE
A	PDR NO.:T211201-1A	TAO	2022.07.22

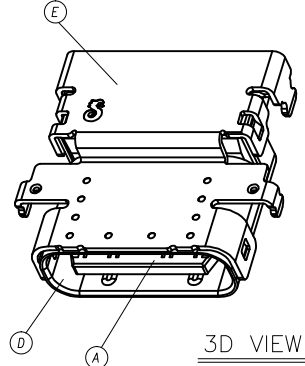
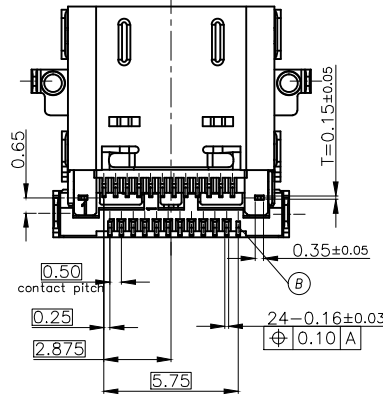
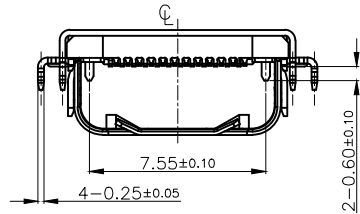
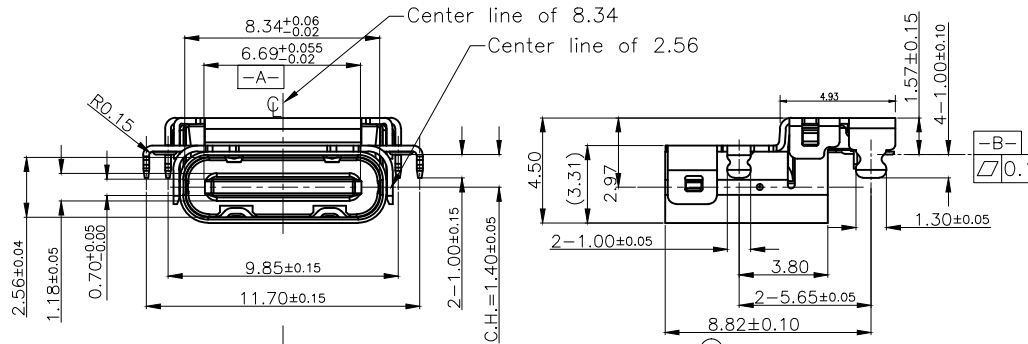
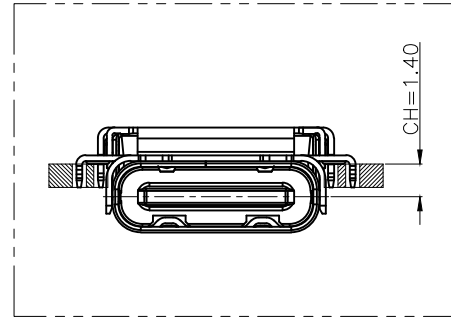
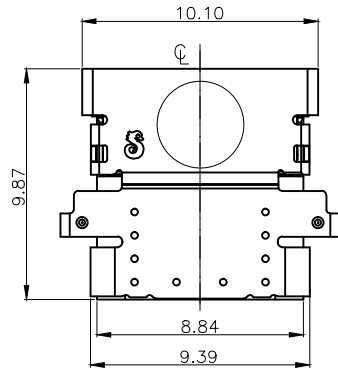

SPECIFICATIONS:  
1. ELECTRICAL CHARACTERISTICS:

- 1-1. LLCR:  
VBUS & GND PINS: 40mΩ /PIN Max.  
OTHER PINS: 40mΩ /PIN Max.  
LLCR MAX. CHANGE OF ALL PINS: 10mΩ.
- 1-2. CURRENT RATING: 3.0 A Max.
- 1-3. VOLTAGE RATING: 5.0 V.
- 1-4. INSULATION RESISTANCE: 100MΩ Min.
- 1-5. ENVIRONMENTAL PERFORMANCE:  
OPERATING TEMPERATURE: -55°C~+85°C.

2. MECHANICAL CHARACTERISTICS:

- 2-1. MATING FORCE : 5N~20N.
- 2-2. UNMATING FORCE : 8N~20N. After 10000 MATING 6N~20N.
- 3. LIFE TEST: 10000 CYCLES Min.
- 4. TO CONFORM TO SINGATRON HAZARDOUS SUBSTANCE FREE SPEC.
- 5. HALOGEN FREE PRODUCT IDENTIFICATION MARK ON JACK:
- 6. HALOGEN FREE PRODUCT IDENTIFICATION LABEL ON PACKAGING:
- 7. FOR REFLOW SOLDERING LEAD-FREE PROCESS.
- 8. MEET USB TYPE C STANDARD SPECIFICATION,

NO	DESCRIPTION	QTY	MATERIAL	PLATING & COLOR
E	TOP SHELL	1	STAINLESS STEEL,T=0.25	80uin Min. Solderable Nickel plating
D	SHELL	1	STAINLESS STEEL,T=0.25	80uin Min. Solderable Nickel plating
C	MID-GND	1	SUS301 T=0.15	80uin Min. Solderable Nickel plating
B	CONTACT	24	C64775-H,T=0.12	30uin Au plating on contact area, G/F plating on solder tail area, and 80uin Min Nickel under plating .
A	BODY	1	LCP 6808U · UL94-V0	BLACK

UNLESS OTHERWISE SPECIFIED TOLERANCES		Singatron Enterprise Co., Ltd. 信音企業股份有限公司	
DECIMALS:	ANGLES:	TITLE	USB TYPE -C Dual SMT (C.H.=1.40) TB14
X :±0.5	X :±2°	DWN	TAO PART NO: 2UB3C40-004111F
X.X :±0.3	X.X :±1°	CHKD	Boye SCALE:4:1 UNIT: mm
X.XX :±0.2		APVD	Liao SIZE: A3 SHEET:1 OF 2 REV:A
CUSTOMER COPY			

REV.	ECN NO OR DESCRIPTION	REVISED	DATE
A	PDR NO.:T211201-1A	TAO	2022.07.22

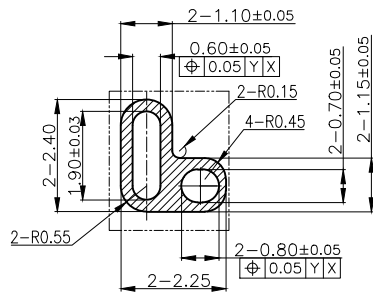
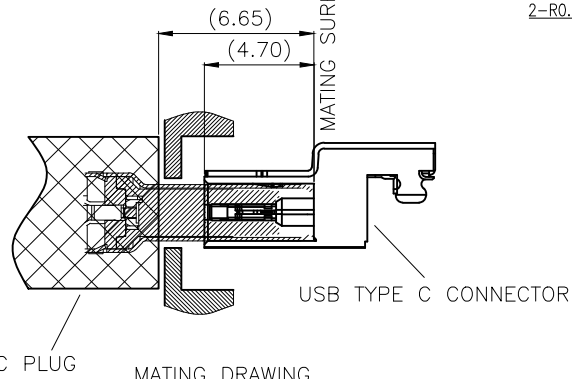
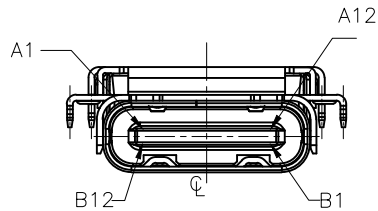
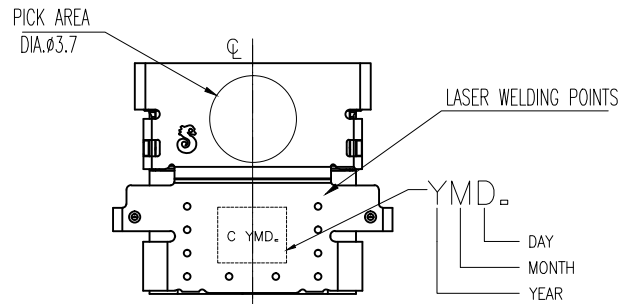

Detail A  
Scale 2:1

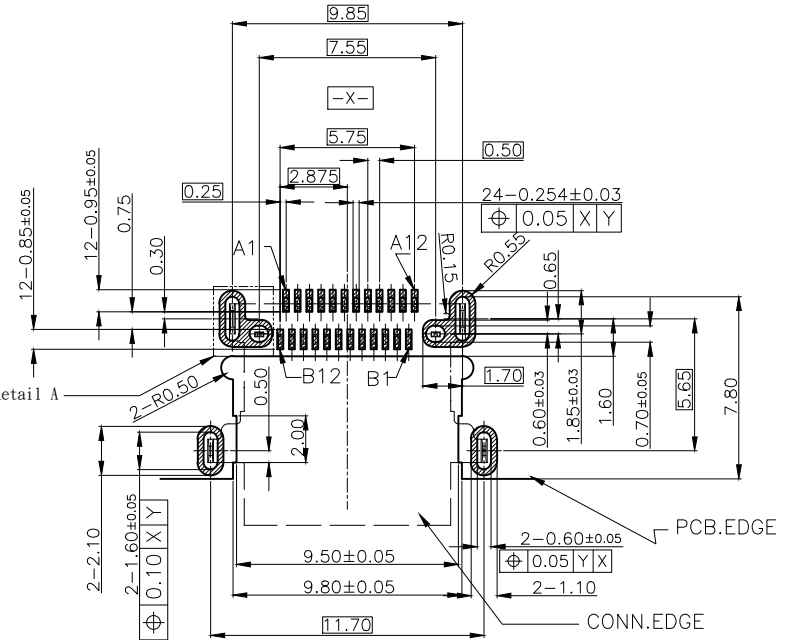

RECOMMENDED P.C.B LAYOUT(TOP VIEW)  
TOLERANCE= $\pm 0.05$ (THK:1.00mm)

NO	DESCRIPTION	QTY	MATERIAL	PLATING & COLOR
UNLESS OTHERWISE SPECIFIED TOLERANCES		Singatron Enterprise Co., Ltd. 信音企業股份有限公司		
DECIMALS: ANGLES:		TITLE: USB TYPE -C Dual SMT (C.H.=-1.40) TBT4		
X : $\pm 0.5$	X : $\pm 2^\circ$	DWN	TAO	PART NO: 2UB3C40-004111F
X.X : $\pm 0.3$	X.X : $\pm 1^\circ$	CHKD	Boye	SCALE:4:1 UNIT: mm
X.XX : $\pm 0.2$		APVD	Liao	SIZE: A3 SHEET:2 OF 2 REV:A
CUSTOMER COPY				