

REV.	ECN NO. OR DESCRIPTION	REVISED	DATE
A	PDR NO.: T181210-2A	Charles	2020.01.11

- SPECIFICATIONS:
- ELECTRICAL CHARACTERISTICS:
    - CURRENT RATING: 1.8A (PIN1,4) ; OTHER CONTACTS 0.25A
    - CONTACT RESISTANCE: 30mΩ MAX.
    - DIELECTRIC WITHSTANDING VOLTAGE: 100V AC FOR 1 MINUTE
    - INSULATION RESISTANCE: 100MΩ MIN
  - TO CONFORM TO SINGATRON HAZARDOUS SUBSTANCE FREE SPEC.
  - HALOGEN PRODUCT IDENTIFICATION LABEL ON JACK: 
  - FOR WAVE SOLDERING LEAD-FREE PROCESS.
  - DATE : YMMDD
  - PACKAGING : TAPE & REEL.
  - ▽ REPRESENT CPK DIMENSIONS.

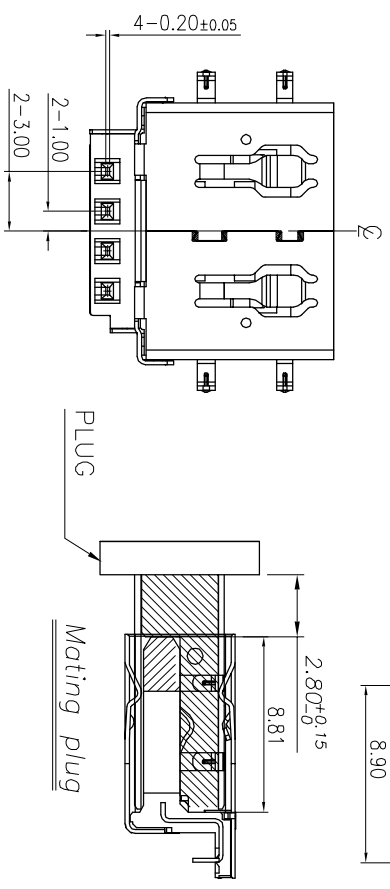
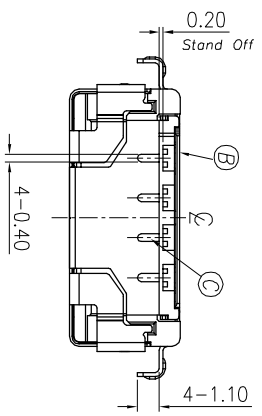
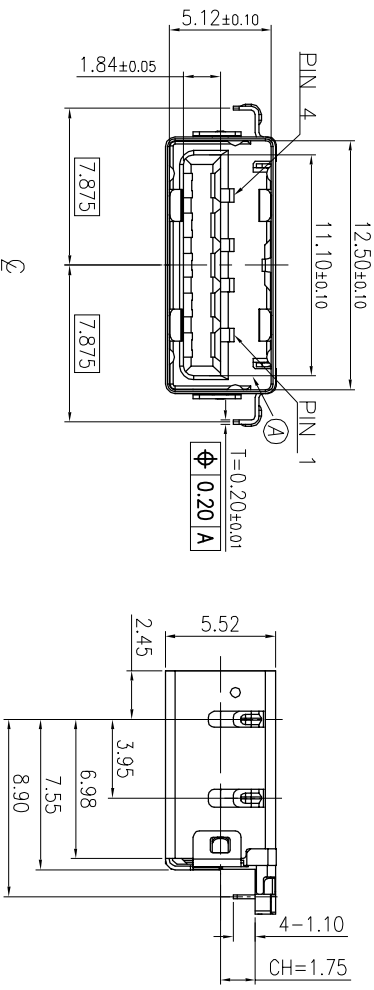
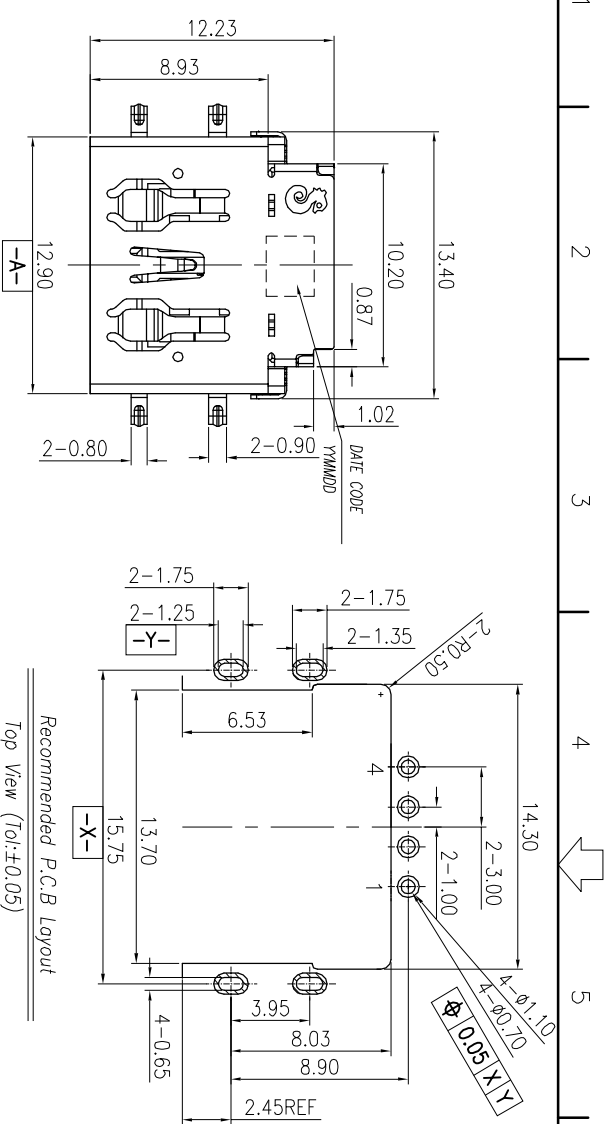

Pin NO.	Signal Assignment
# 1	VBUS
# 2	D-
# 3	D+
# 4	GND

NO	DESCRIPTION	QTY	MATERIAL	PLATING & COLOR
C	TERMINAL	4	COPPER ALLOY	
B	SHELL	1	SUS304-1/2H 0.20t	GOLD FLASH ON MATING AREA, MADE IN 100%, PLATED ON SOLDERING 50% NICKEL UNDER PLATING OVER ALL.
A	BODY	1	THERMOPLASTIC, UL94V-0	NICKEL 60u" MIN BLACK

UNLESS OTHERWISE SPECIFIED TOLERANCES

Singatron Enterprise Co., Ltd.  
信晉企業股份有限公司

TITLE	DECIMALS:	ANGLES:
USB 2.0 REVERSE CONNECTOR	X : ±0.5	X : ±2°
	XX : ±0.3	X.X : ±1°
	XXX : ±0.2	

APVD: Boye SIZE: A3 SHEET: 10F1 REV: A

CUSTOMER COPY