

Recommended P.C.B Layout  
(TOP VIEW) TOLERANCE=±0.05

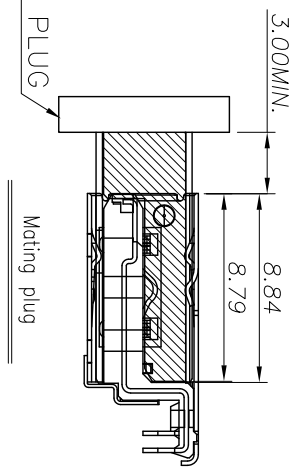
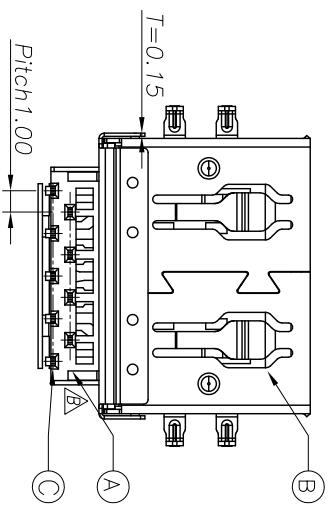
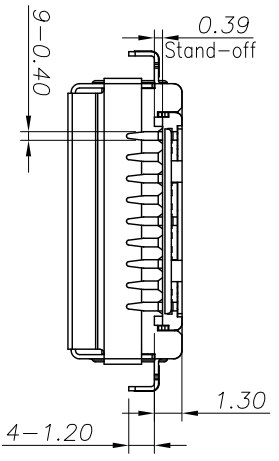
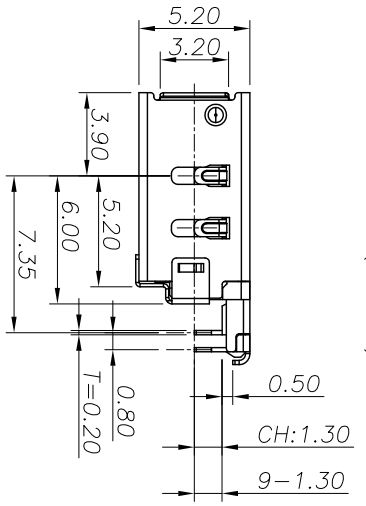
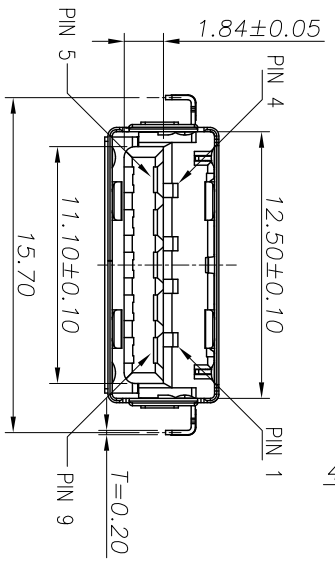

REV.	ECN NO.	OR DESCRIPTION	REVISED	DATE
A	PDR NO:1720325-2A		PAN	2022.08.11
B	ECN NO:S202212-C18		LIRUI	2023.02.10

- SPECIFICATIONS:
- ELECTRICAL CHARACTERISTICS:
    - CURRENT RATING: 1.8A (PIN1,4) ; OTHER CONTACTS 0.25A
    - CONTACT RESISTANCE: 30mΩ MAX.
    - DIELECTRIC WITHSTANDING VOLTAGE: 100V AC FOR 1 MINUTE
    - INSULATION RESISTANCE: 100MΩ MIN
  - MECHANICAL CHARACTERISTICS:
    - INSERTION FORCE : 3.57 Kgf Max.
    - WITHDRAWAL FORCE : 2.54 Kgf Max., 1.02 Kgf Min.
    - DURABILITY: 1,500 CYCLES,
    - TO CONFORM TO SINGATRON HAZARDOUS SUBSTANCE FREE SPEC.
    - HALOGEN PRODUCT IDENTIFICATION MARK ON JACK: ©
    - HALOGEN PRODUCT IDENTIFICATION LABEL ON PACKAGING:
    - FOR WAVE SOLDERING LEAD-FREE PROCESS.
    - DATE : YMMDD
    - PACKAGING : TAPE & REEL.

Pin Number	Signal ASSIGNMENT
PIN 1	VBUS
PIN 2	D-
PIN 3	D+
PIN 4	GND
PIN 5	SDA_SSRX-
PIN 6	SDA_SSRX+
PIN 7	GND_DRAIN
PIN 8	SDA_SSTX-
PIN 9	SDA_SSTX+

NO	DESCRIPTION	QTY	MATERIAL	PLATING & COLOR
D	SHELL COVER	1	SUS430	T=0.15
C	TERMINAL	9	COPPER ALLOY	
B	SHELL	1	SUS304	T=0.20
A	HOUSING	1	PART	60µm Min. SOLDERABLE Ni PLATING
NO	DESCRIPTION	QTY	MATERIAL	PLATING & COLOR

UNLESS OTHERWISE SPECIFIED TOLERANCES

Singatron Enterprise Co., Ltd.  
信登企業股份有限公司

TITLE: USB 3.0 REVERSE CONNECTOR

DECIMALS: ANGLES:

X : ±0.5 X : ±2°  
X.X : ±0.3 X.X : ±1°  
X.XX : ±0.2

CHKD: LIRUI PART NO.: ZUB3M04-058201F  
APVD: boye SCALE: 1:1 UNIT: mm SHEET: 1 OF 1 REV: B

CUSTOMER COPY