

Recommended P.C.B Layout
(TOP VIEW) TOLERANCE=±0.05

SPECIFICATIONS:

- ELECTRICAL CHARACTERISTICS:
 - CURRENT RATING: 1.8A (PIN1,4) ; OTHER CONTACTS 0.25A
 - CONTACT RESISTANCE: 30mΩ MAX.
 - DIELECTRIC WITHSTANDING VOLTAGE: 100V AC FOR 1 MINUTE
 - INSULATION RESISTANCE: 100MΩ MIN
- MECHANICAL CHARACTERISTICS:
 - INSERTION FORCE : 2.5 Kgf MAX
 - WITHDRAWAL FORCE : 1.0 Kgf MIN(INITIAL),0.8 Kgf MIN(AFTER TEST)
 - DURABILITY: 5,000 CYCLES.
 - TO CONFORM TO SINGATRON HAZARDOUS SUBSTANCE FREE SPEC.
 - HALOGEN FREE IDENTIFICATION MARK ON JACK: Ⓢ
 - HALOGEN FREE IDENTIFICATION LABEL ON PACKAGING: Ⓢ
 - FOR IR REFLOW PROCESS.
 - DATE : YYMMDD or YMD
 - PACKAGING : TAPE & REEL.

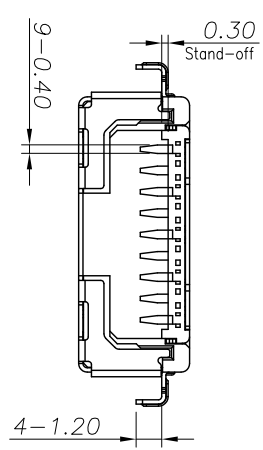
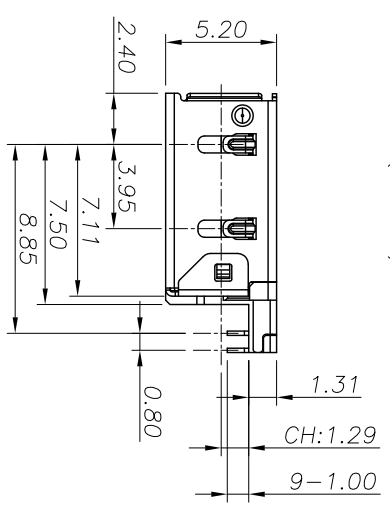
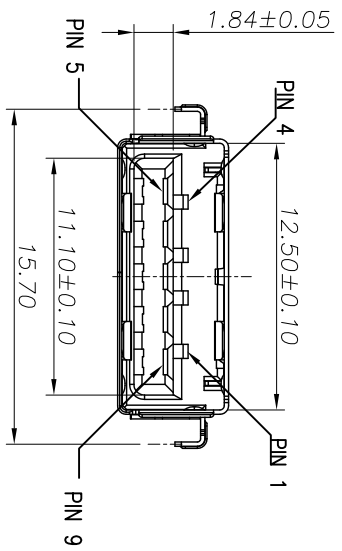

Gen 2

Pin Number	Signal ASSIGNMENT
PIN 1	VBUS
PIN 2	D-
PIN 3	D+
PIN 4	GND
PIN 5	SIDA_SSRX-
PIN 6	SIDA_SSRX+
PIN 7	GND_DRAIN
PIN 8	SIDA_SSTX-
PIN 9	SIDA_SSTX+

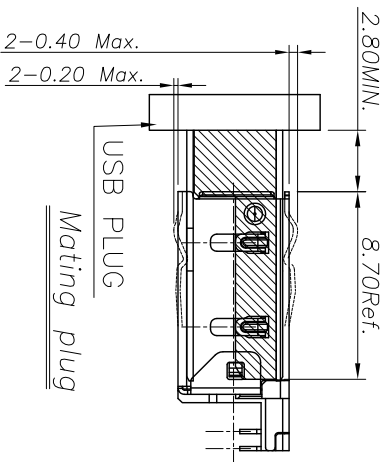
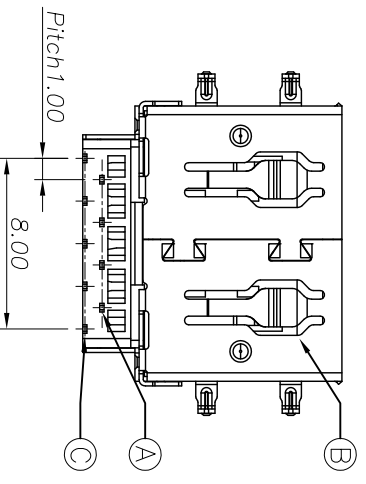

NO	DESCRIPTION	QTY	MATERIAL	PLATING & COLOR
C	TERMINAL	9	COPPER ALLOY	10um Au PLATED ON MATING AREA, Matt. Sn 40-80um, PLATED ON SOLDERING 60um NICKEL UNDER PLATING OVERALL
B	SHELL	1	SUS304	60um Min. Solderable Nickel platin
A	HOUSING	1	HIGH THERMOPLASTIC	UL94 V-0 BLACK
NO	DESCRIPTION	QTY	MATERIAL	PLATING & COLOR

Singatron Enterprise Co., Ltd.
信營企業股份有限公司

DECIMALS:	ANGLES:	TITLE	HAOLAN PART NO.	SCALE	UNIT	REV.
X : ±0.5	X : ±2°	USB 3.0 REVERSE CONNECTOR	2UB3M04-059201F	1:1	mm	A
X.X : ±0.3	X.X : ±1°	CHKD ALLEN	SIZE: A3			REV:A
X.XX : ±0.2		APVD Boye	SHEET: 1 OF 1			

CUSTOMER COPY