

REV.	ECN NO OR DESCRIPTION	REVISED	DATE
A	PDR NO. T230518-5A	ALLEN	2023.07.21

Date code(YMMDD)

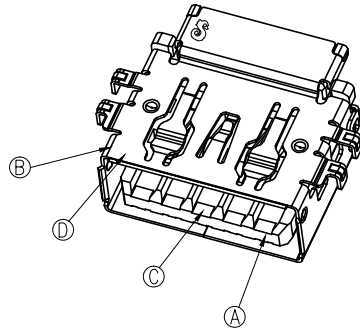
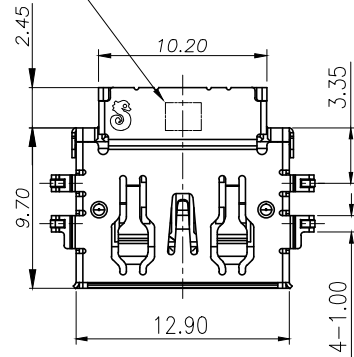

SPECIFICATIONS:

- ELECTRICAL CHARACTERISTICS:
 - CURRENT RATING: 2.0A (PIN1,4) ; OTHER CONTACTS 0.25A
 - CONTACT RESISTANCE: 30mΩ MAX.
 - DIELECTRIC WITHSTANDING VOLTAGE: 500V AC FOR 1 MINUTE
 - INSULATION RESISTANCE: 100MΩ MIN
- MECHANICAL CHARACTERISTICS:
 - INSERTION FORCE : 35N MAX. INITIAL.
 - WITHDRAWAL FORCE : 10N MIN. INITIAL, 8N MIN. FOR AFTER TEST.
- DURABILITY: 5,000 CYCLES,
- OTHER SPEC TO REFER USB 3.1 SPEC.
- TO CONFORM TO SINGATRON HAZARDOUS SUBSTANCE FREE SPEC.
- HALOGEN FREE PRODUCT IDENTIFICATION MARK : ⊙
- HALOGEN FREE PRODUCT IDENTIFICATION LABEL ON PACKAGING:
- FOR REFLOW SOLDERING LEAD-FREE PROCESS.
- PACKAGING : TAPE & REEL.

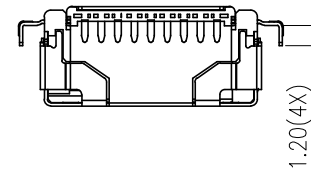
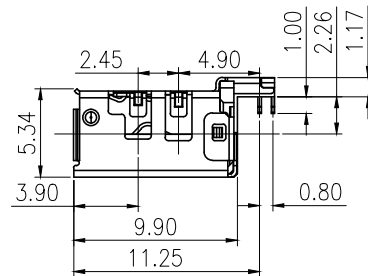
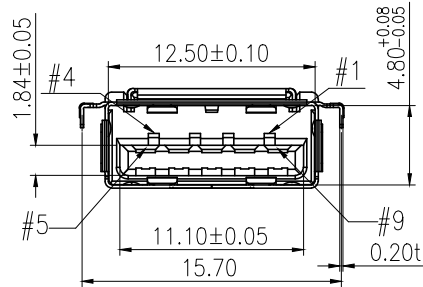

Pin Number	Signal ASSIGNMENT
PIN 1	VBUS
PIN 2	D-
PIN 3	D+
PIN 4	GND
PIN 5	StdA_SSRX-
PIN 6	StdA_SSRX+
PIN 7	GND_DRAIN
PIN 8	StdA_SSTX-
PIN 9	StdA_SSTX+

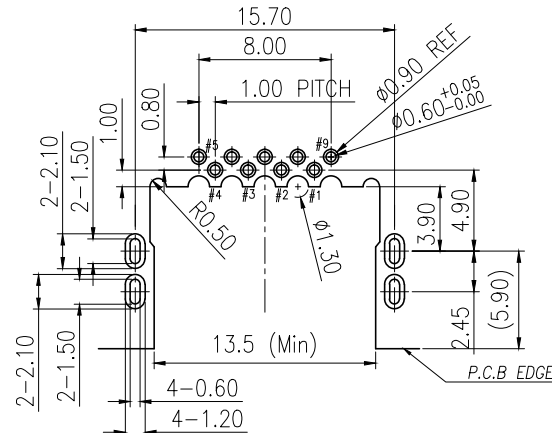
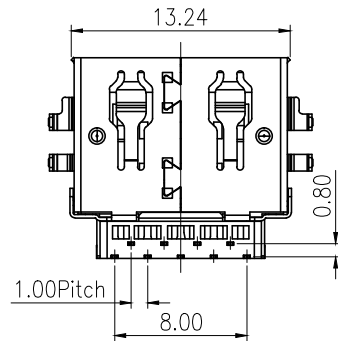

Recommended P.C.B Layout (THK:1.0mm)
Top View (Tol:±0.05)

C	9P TERMINAL	9	COPPER ALLOY	GOLD FLASH PLATED ON MATING AREA, Matte.Sn 100u"Min.PLATED ON SOLDERING 60u"NICHEL UNDER PLATING OVERALL
B	SHELL	1	SUS304 1/2H	NICKEL 60u"MIN
A	HOUSING	1	HIGH-THERMAL PLASTIC UL94-V0	BLACK
NO	DESCRIPTION	QTY	MATERIAL	PLATING & COLOR
UNLESS OTHERWISE SPECIFIED TOLERANCES		Singatron Enterprise Co., Ltd. 信音企業股份有限公司		
DECIMALS: X :±0.5 X.X :±0.3 X.XX :±0.2		TITLE: USB 3.0 REVERSE CONNECTOR		
ANGLES: X :±2° X.X :±1°		DWN BING PART NO.2UB3M04-081201F		
		CHKD ALLEN SCALE 1:1 UNIT: mm		
		APVD BOYE SIZE: A3 SHEET:1 OF 1 REV:A		
CUSTOMER COPY				