

Pin Number	PIN 1	PIN 2	PIN 3	PIN 4	PIN 5	PIN 6	PIN 7	PIN 8	PIN 9
Signal ASSIGNMENT	VBUS	D-	D+	GND	Stda_SSRX-	Stda_SSRX+	GND_DRAIN	Stda_SSTX-	Stda_SSTX+

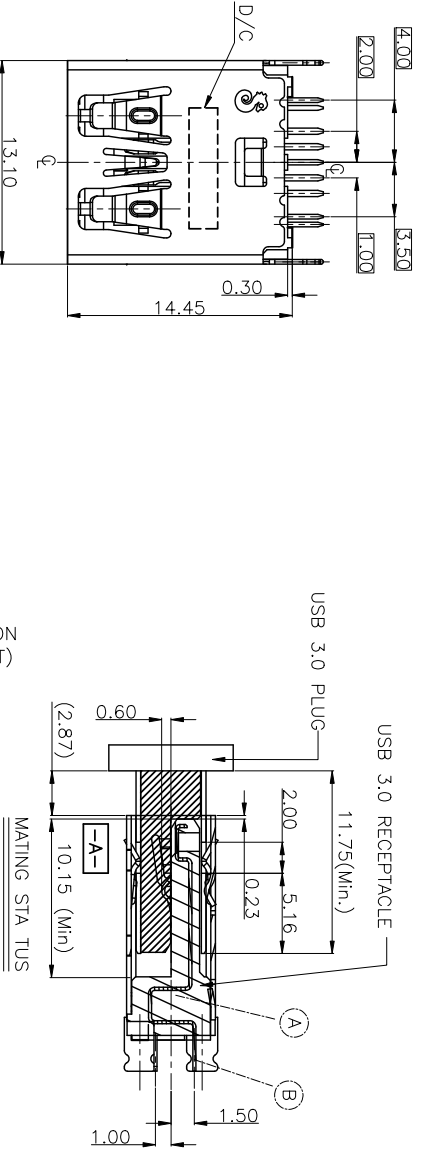

- SPECIFICATIONS:
- ELECTRICAL CHARACTERISTICS:
 - CURRENT RATING: 1.8A (PIN1,4); OTHER CONTACTS 0.25A.
 - CONTACT RESISTANCE: 30m Ω Max.
 - DIELECTRIC WITHSTANDING VOLTAGE: 100V AC FOR 1 MINUTE.
 - INSULATION RESISTANCE: 100M Ω Min.
 - MECHANICAL CHARACTERISTICS:
 - INSERTION FORCE: 3.5kgf Max.
 - WITHDRAWAL FORCE: 1.0kgf~2.5kgf Min.(INITIAL), 0.8kgf~2.5kgf.(AFTER TEST).
 - DURABILITY: 5,000 CYCLES.
 - TO CONFORM TO SINGARTRON HAZARDOUS SUBSTANCE FREE SPEC.
 - HALOGEN FREE IDENTIFICATION MARK ON JACK.Ⓢ
 - HALOGEN FREE IDENTIFICATION LABEL ON PACKAGING.
 - FOR REFLOW SOLDERING LEAD-FREE PROCESS.
 - DATE: YYMMDD.
 - PACKAGING: TAPE & REEL.

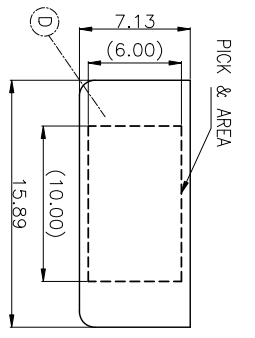
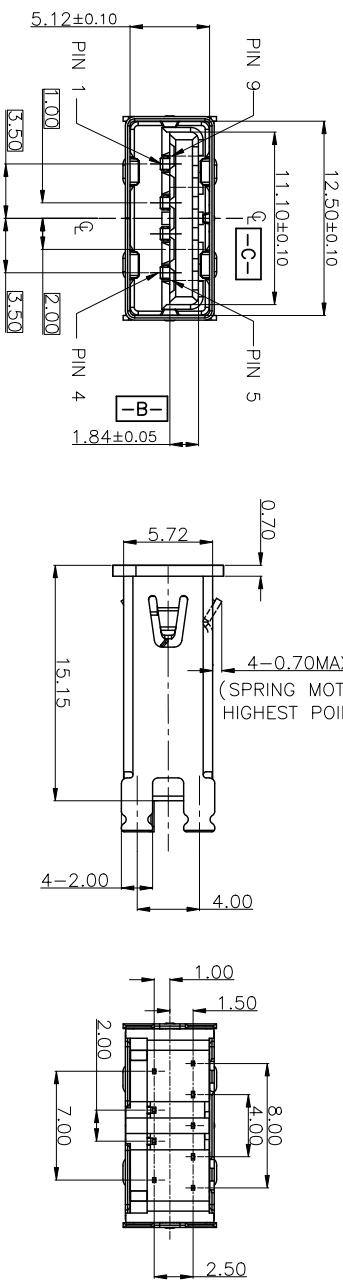

3D VIEW

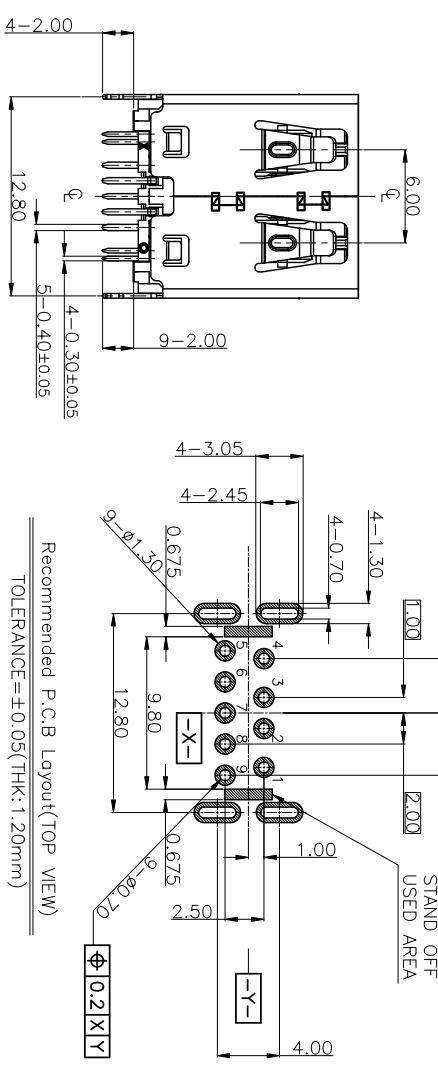
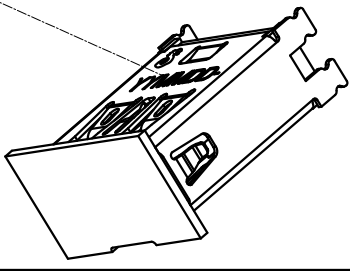

Recommended P.C.B Layout(TOP VIEW)
TOLERANCE=±0.05(THK:1.20mm)

D	CAP	1	HIGH TEMP.THERMOPLASTIC	BLACK
C	SHELL	1	STAINLESS STEEL,T=0.30	90µm Min. Solderable Nickel platin
B	9 PIN TERMINAL	1	COPPER ALLOY, T=0.20	120µm Min.Matte Tin Plating on solder (all area) and 60µm Min. Nickel under Plating
A	BODY	1	HIGH TEMP.THERMOPLASTIC	BLACK
NO	DESCRIPTION	QTY	MATERIAL	PLATING & COLOR

Singatron Enterprise Co., Ltd.
信音企業股份有限公司

UNLESS OTHERWISE SPECIFIED TOLERANCES

DECIMALS:	ANGLES:
X :±0.5	X :±2°
X.X :±0.3	X.X :±1°
X.XX :±0.2	

TITLE	USB 3.1 VERTICAC TYPE
DWN	HAOLIAN PART NO:2UB3M12-001201F
CHKD	ALLEN SCALE:4:1 UNIT: mm
APVD	boye SIZE: A3 SHEET:1 OF 1 REV:B

CUSTOMER COPY