

Pin Number	PIN 1	PIN 2	PIN 3	PIN 4	PIN 5	PIN 6	PIN 7	PIN 8	PIN 9
Signal ASSIGNMENT	VBUS	D-	D+	GND	Stda_SSRX-	Stda_SSRX+	GND_DRAIN	Stda_SSTX-	Stda_SSTX+

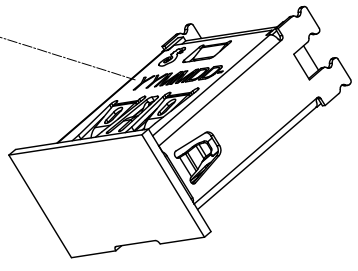

- SPECIFICATIONS:
- ELECTRICAL CHARACTERISTICS:
    - CURRENT RATING: 1.8A (PIN1-4), OTHER CONTACTS 0.25A.
    - CONTACT RESISTANCE: 30mΩ Max.
    - DIIELECTRIC WITHSTANDING VOLTAGE: 100V AC FOR 1 MINUTE.
    - INSULATION RESISTANCE: 100MΩ Min.
  - MECHANICAL CHARACTERISTICS:
    - INSERTION FORCE: 3.5kgf Max.
    - WITHDRAWAL FORCE: 1.0kgf~2.5kgf Min.(INITIAL), 0.8kgf~2.5kgf(AFTER TEST).
    - DURABILITY: 5,000 CYCLES.
    - TO CONFORM TO SINGARON HAZARDOUS SUBSTANCE FREE SPEC.
    - HALOGEN FREE IDENTIFICATION MARK ON JACK.Ⓢ
    - HALOGEN FREE IDENTIFICATION LABEL ON PACKAGING.
    - FOR REFLOW SOLDERING LEAD-FREE PROCESS.
    - DATE: YYMMDD.
    - PACKAGING: TAPE & REEL.

REV.	ECN NO	OR DESCRIPTION	REVISED	DATE
A	PDR NO: 1210520-4A		haolan	2021.12.24
B	ECN NO: S202302-009		HAOLIAN	2023.05.23

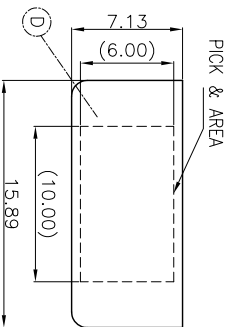
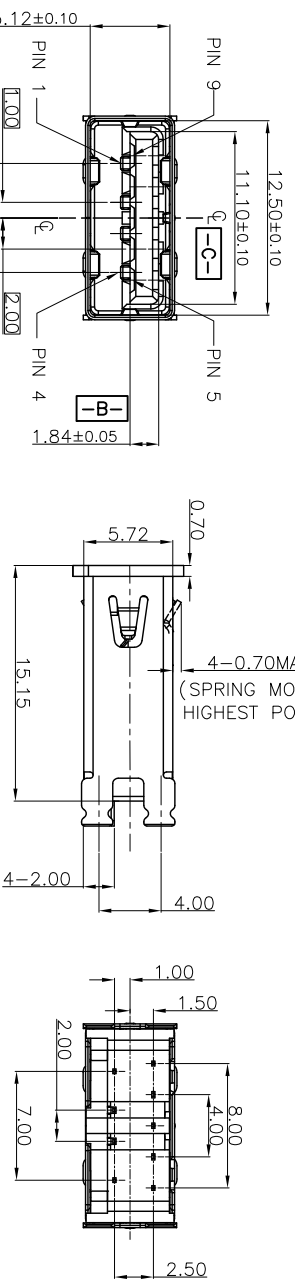
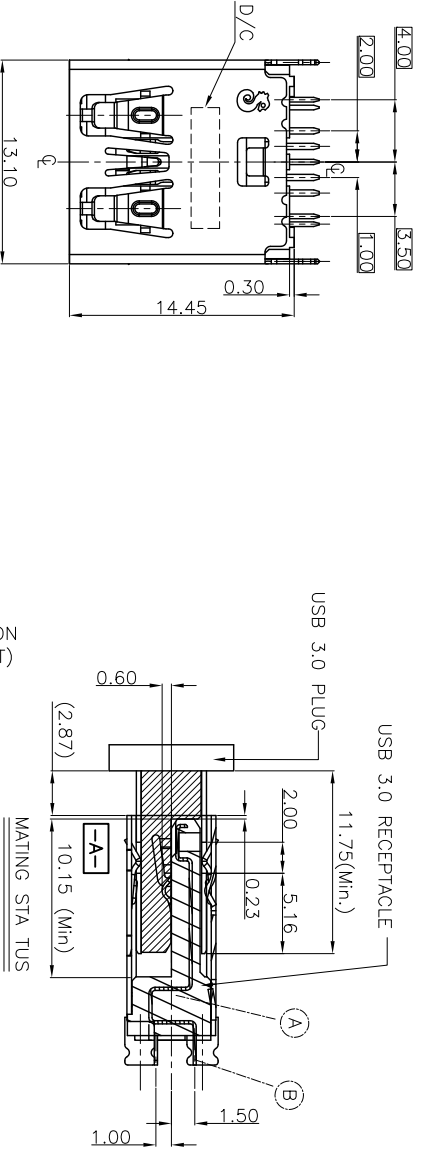
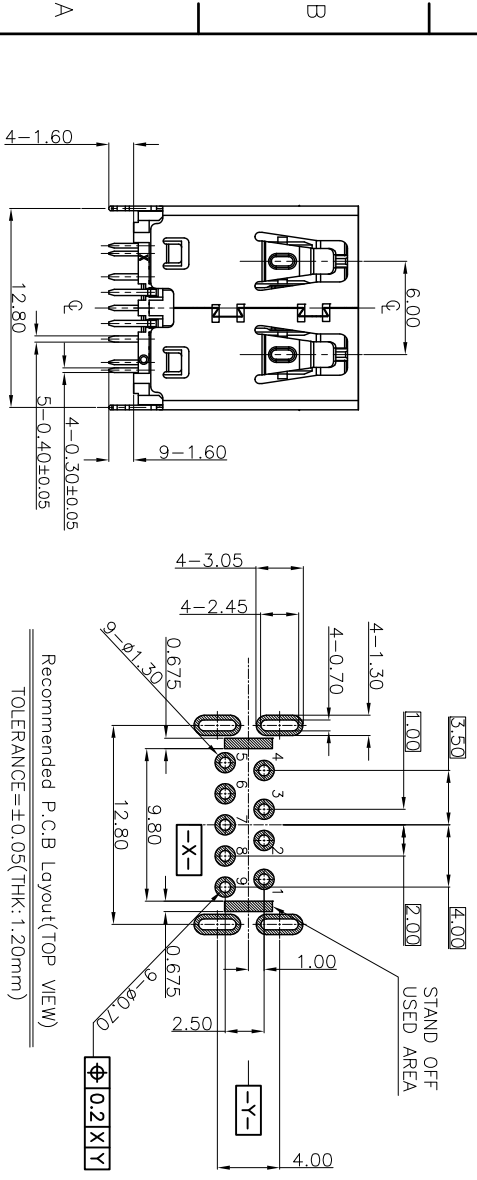

D	CAP	1	HIGH TEMP.THERMOPLASTIC	BLACK
C	SHELL	1	STAINLESS STEEL,T=0.30	60μm Min. Solderable Nickel platin
B	9 PIN TERMINAL	1	COPPER ALLOY, T=0.20	120μm Min.Wettable Tin Plating on solder ball area and 60μm Min. Nickel under Plating
A	BODY	1	HIGH TEMP.THERMOPLASTIC	RED 1795C (R8)
NO	DESCRIPTION	QTY	MATERIAL	PLATING & COLOR

UNLESS OTHERWISE SPECIFIED TOLERANCES

Singatron Enterprise Co., Ltd.  
信亨企業股份有限公司

DECIMALS:	ANGLES:	TITLE	USB 3.0 VERTICAL TYPE
X :±0.5	X :±2°	DWM	HAOLIAN PART NO:2UB3M12-002201F
X.X :±0.3	X.X :±1°	CHKD	ALLEN SCALE:4:1 UNIT: mm
X.XX :±0.2		APVD	BOYE SIZE: A3 SHEET: 1 OF 1 REV: B

CUSTOMER COPY