

Pin Number	PIN 1	PIN 2	PIN 3	PIN 4	PIN 5	PIN 6	PIN 7	PIN 8	PIN 9
Signal ASSIGNMENT	VBUS	D-	D+	GND	Stda_SSRX-	Stda_SSRX+	GND_DRAIN	Stda_SSTX-	Stda_SSTX+

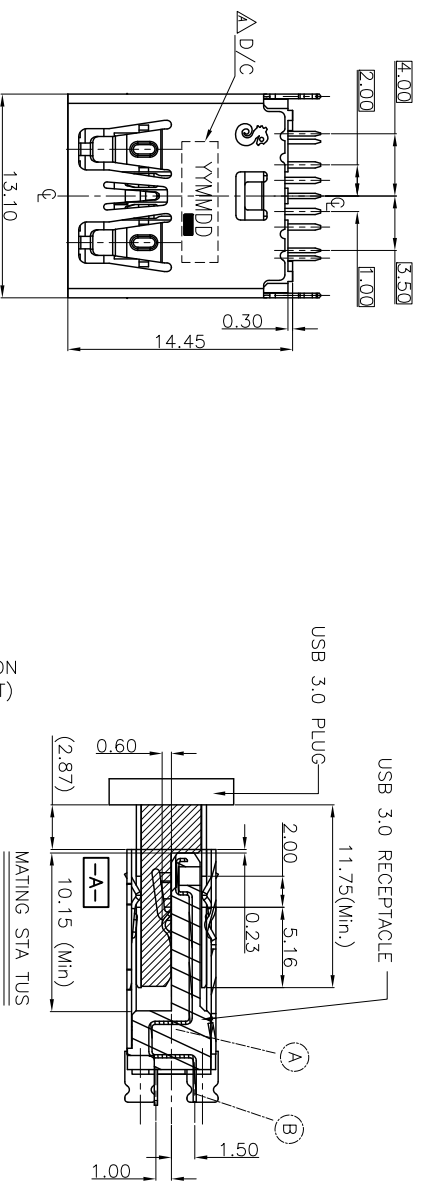

- USB 3.0 PLUG
- USB 3.0 RECEPTACLE
- MATING STATION
- SPECIFICATIONS:
- ELECTRICAL CHARACTERISTICS:
    - CURRENT RATING: 1.8A (PIN1,4); OTHER CONTACTS 0.25A.
    - CONTACT RESISTANCE: 30mΩ Max.
    - DIELECTRIC WITHSTANDING VOLTAGE: 100V AC FOR 1 MINUTE.
    - INSULATION RESISTANCE: 100MΩ Min.
  - MECHANICAL CHARACTERISTICS:
    - INSERTION FORCE: 3.5kgf Max.
    - WITHDRAWAL FORCE: 1.0kgf~2.5kgf Min.(INITIAL), 0.8kgf~2.5kgf.(AFTER TEST).
    - DURABILITY: 5,000 CYCLES.
    - TO CONFORM TO SINGATRON HAZARDOUS SUBSTANCE FREE SPEC.
    - HALOGEN FREE IDENTIFICATION MARK ON JACK.Ⓢ
    - HALOGEN FREE IDENTIFICATION LABEL ON PACKAGING.
    - FOR REFLOW SOLDERING LEAD-FREE PROCESS.
    - DATE: YYMMDD.
    - PACKAGING: TAPE & REEL.

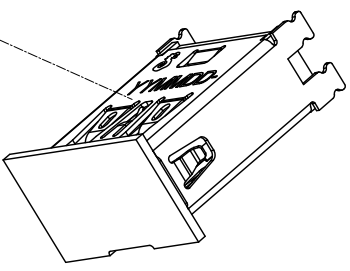
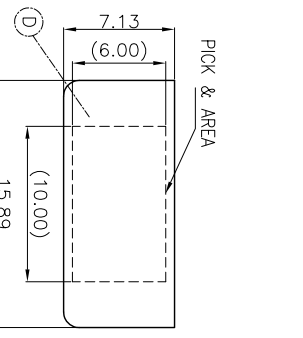
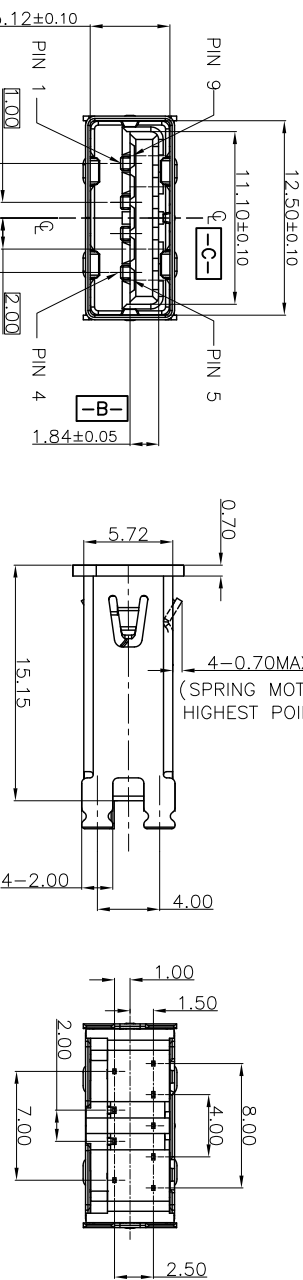

3D VIEW

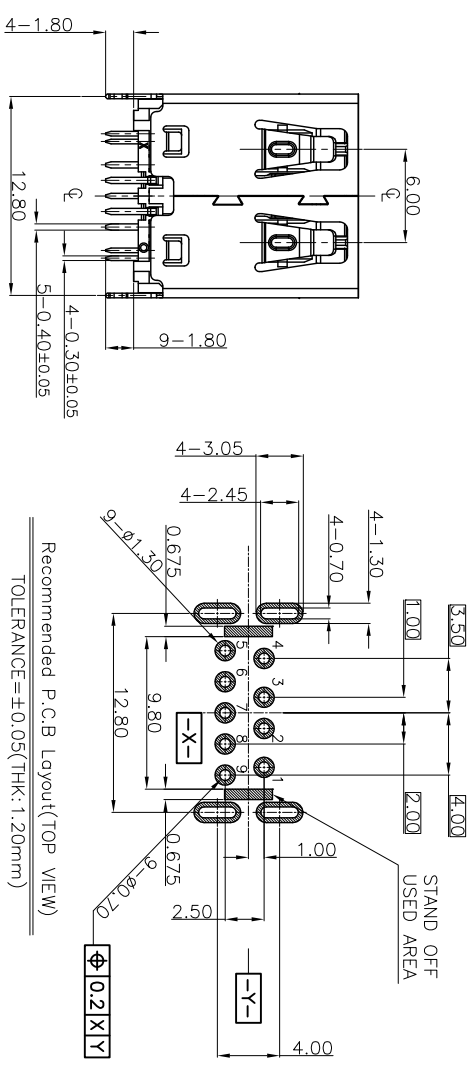

NO	DESCRIPTION	QTY	MATERIAL	PLATING & COLOR
D	CAP	1	HIGH TEMP.THERMOPLASTIC	BLACK
C	SHELL	1	STAINLESS STEEL,T=0.30	60μn Min. Solderable Nickel platin
B	9 PIN TERMINAL	1	COPPER ALLOY, T=0.20	120μn Min. Matte Tin Plating on solder (all area) and 60μn Min. Nickel under Plating
A	BODY	1	HIGH TEMP.THERMOPLASTIC	BLUE(3000°)

UNLESS OTHERWISE SPECIFIED TOLERANCES

DECIMALS: ANGLES:

±0.5 X ±2°

±0.3 X.X ±1°

±0.2 X.XX

Recommended P.C.B Layout(TOP VIEW)

TOLERANCE=±0.05(THK:1.20mm)

0.2 X Y

Singatron Enterprise Co., Ltd.  
信亨企業股份有限公司

USB 3.1 VERTICAL TYPE

HAOLIAN PART NO:2UB3M12-003201F

APVD boye SIZE: A3 SHEET: 1 OF 1 REV:B

CUSTOMER COPY