

Pin No.	D1	D2	D3	D4
Pin No.	C1	C2	C3	C4
Pin No.	B1	B2	B3	B4
Pin No.	A1	A2	A3	A4
SIGNAL NAME	VBUS	D-	D+	GND

- Remark:
- Characteristics:
 - 1.1 Rating Voltage : 30V AC.
 - 1.2 Rating Current:1.5A
 - 1.3 Contact Resistance:30 mΩ MAX.
 - 1.4 Insulation Resistance:100 MΩ MIN.
 - 1.5 Withstanding Voltage:AC 500V.
 - 1.6 Mating force : 3.57kgf MAX
 - 1.7 Extraction force :1kgf~3.57kgf
After durability:0.8 kgf Min
 - 1.8 Life test:5000Cycles MIN.
 - 1.9 Temperature Range: -30℃~+85℃.
 - 2.0 Recommended Process: wave solder 270℃, 5 seconds.
 - 2.1 Insertion force of connector into PCB 2kgf Max
 - 2.2 Salt Spray test 48H PASS
- HALOGEN FREE PRODUCT IDENTIFICATION
 - MARK ON PRODUCT:
 - HALOGEN FREE PRODUCT IDENTIFICATION LOGO ON THE PACKAGING:

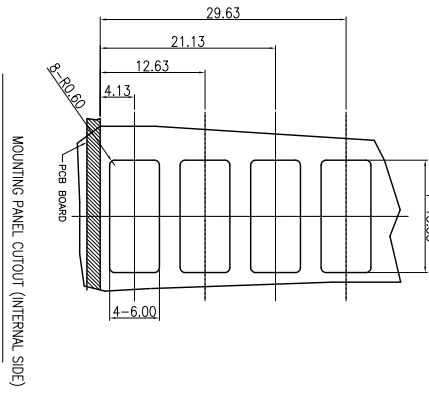
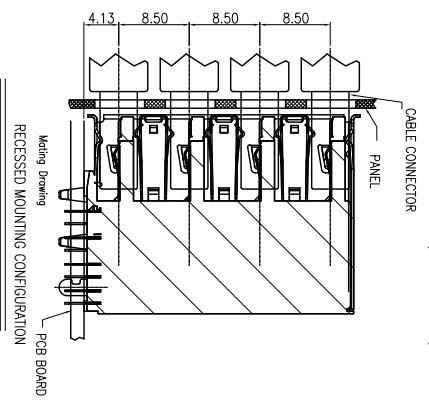

H	BACK COVER 2	1	LCP	UL 94V-0, COLOR BLACK
G	BACK COVER 1	1	LCP	UL 94V-0, COLOR BLACK
F	2-HSG(3~4#)	1	PA9T	UL 94V-0, COLOR BLACK
E	1-HSG(1~2#)	1	PA9T	UL 94V-0, COLOR BLACK
D	USB2 CONTACT(C1~D4)	8	C44500	1u" Au PLATED ON CONTACT AREA 80u" Min TIN(NATTE) PLATED ON SOLDER AREA, 500u" Min IN UNDERPLATING OVER ALL
C	USB2 CONTACT(A1~B4)	8	G5191	
B	FINGER	3	SUS201	CLEAN
A	REAR SHELL	1	SUS201	CLEAN
A	FRONT SHELL	1	SUS201	TIN PLATING ONLY AT KINKS,NO PLATING AT THE OTHER ARED
NO	DESCRIPTION	QTY	MATERIAL	PLATING & COLOR

UNLESS OTHERWISE SPECIFIED TOLERANCES

DECIMALS: ANGLES:

X :±0.5 X :±2°
X.X :±0.3 X.X :±1°
X.XX :±0.2

Singatron Enterprise Co., Ltd.
信音企業股份有限公司

TITLE: 四孔USB 2.0 18P DIP TYPE

DWM JIANGTAO PART NO. 2UB3Y89-000111F
CHKD ALLEN SCALE 1:1 UNIT: mm
APVD BOYE SIZE: A3 SHEET: 10F1 REV: A

CUSTOMER COPY