



- SPECIFICATIONS:**
- ELECTRICAL CHARACTERISTICS:**
 - CURRENT RATING: 1.8A (PIN1,4) ; OTHER CONTACTS 0.25A
 - CONTACT RESISTANCE: 30mΩ MAX.
 - DIELECTRIC WITHSTANDING VOLTAGE: 100V AC FOR 1 MINUTE
 - INSULATION RESISTANCE: 100MΩ MIN.
 - MECHANICAL CHARACTERISTICS:**
 - INSERTION FORCE : 3.5 Kgf MAX.
 - WITHDRAWAL FORCE : 1.0 Kgf MIN(INITIAL),0.8 Kgf(AFTER TEST)
 - DURABILITY:** 5,000 CYCLES.
 - TO CONFORM TO SINGATRON HAZARDOUS SUBSTANCE FREE SPEC.**
 - HALOGEN FREE IDENTIFICATION MARK ON JACK:** 
 - HALOGEN FREE IDENTIFICATION LABEL ON PACKAGING:** 
 - FOR IR REFLOW PROCESS.**
 - DATE :** YYMMDD
 - PACKAGING :** TAPE & REEL.



Recommended P.C.B Layout THICKNESS=1.0mm
Component Side TOLERANCE=±0.03 (Top View)

REV.	ECN NO.	OR DESCRIPTION	REVISED	DATE
A		PRODUCT RELEASE	Duke	2013.12.02
B	ECN NO.:S140509		SEAN	2014.09.02

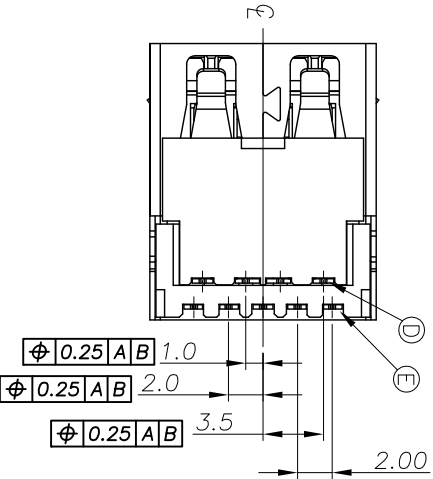
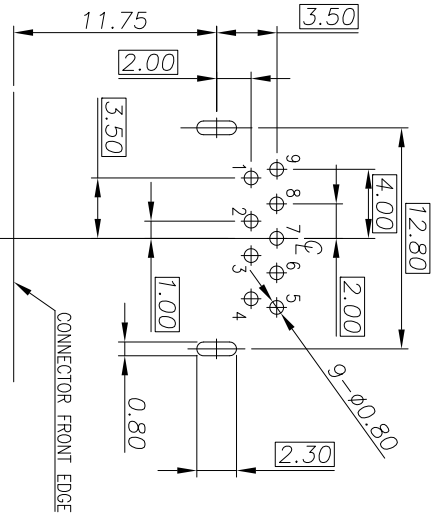
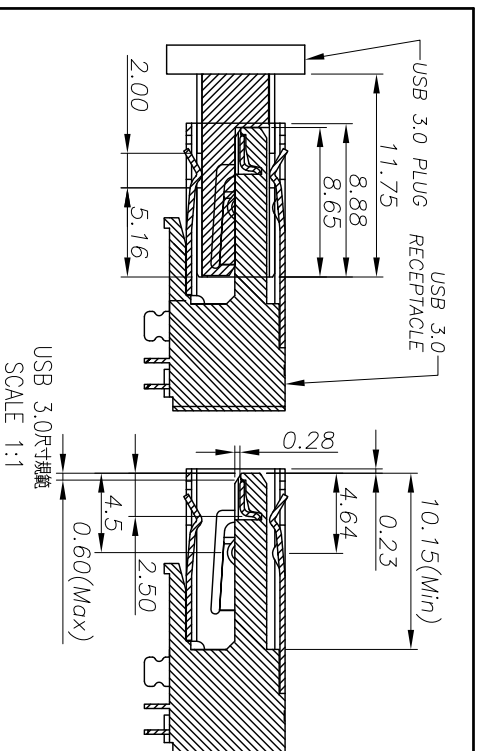
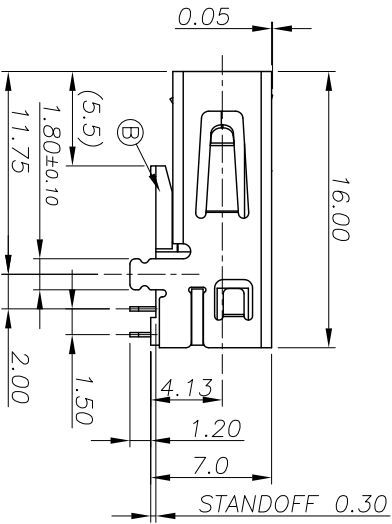
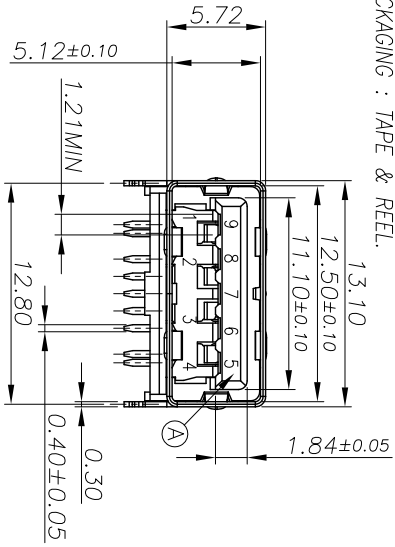
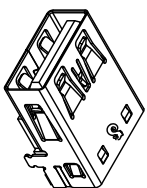
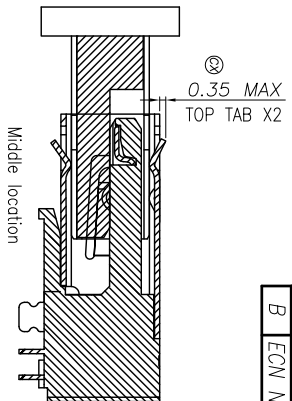
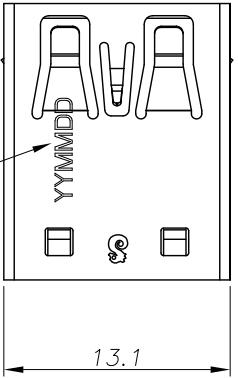
NO	DESCRIPTION	QTY	MATERIAL	PLATING & COLOR
E	TERMINAL	5	BRASS	
D	TERMINAL	4	PHOSPHOR BRONZE	
C	SHELL	1	SUS	NICKEL 60U"MIN
B	BASE	1	PA9T	BLUE
A	HOUSING	1	PA9T	BLUE
NO	DESCRIPTION	QTY	MATERIAL	PLATING & COLOR

UNLESS OTHERWISE SPECIFIED TOLERANCES

DECIMALS: ANGLES:

X :±0.5 X :±2°
X.X :±0.3 X.X :±1°
X.XX :±0.2

TITLE: USB 3.0 CONNECTOR
PART NO.:ZUB4001-600301F

CHKD: CERRY SCALE 1:1 UNIT: mm

APVD: LUSSEN SIZE: A3 SHEET: 1 OF 1 REV: B

Singatron Enterprise Co., Ltd.
信亨企業股份有限公司

CUSTOMER COPY

A B C D E F

1 2 3 4 5 6 7 8