

Recommended P.C.B Layout (THK: 1.0mm)
Top View (Tol: ±0.05)

REV.	ECN NO. OR DESCRIPTION	REVISED	DATE
B	ECN NO: C110368, 修改尺寸和電線規格符合標準要求	ZHOU Q	2012.01.05
C	ECN: C120382 MODIFY DRAWING	DAOWEN	2012.12.27
D	ECN: NO: C120371 MODIFY BODY	BILLY	2013.05.23

SPECIFICATIONS:

- ELECTRICAL CHARACTERISTICS:
 - CURRENT RATING: 1.8A (PIN1,4) ; OTHER CONTACTS 0.25A
 - CONTACT RESISTANCE: 30mΩ MAX
 - ELECTRIC WITHSTANDING VOLTAGE: 100V AC FOR 1 MINUTE
 - INSULATION RESISTANCE: 100M ΩMIN
- MECHANICAL CHARACTERISTICS:
 - INSERTION FORCE : 3.5 Kgf MAX
 - WITHDRAWAL FORCE : 1.0 Kgf MIN
- DURABILITY: 5,000 CYCLES.
- OTHER SPEC TO REFER USB 3.0 SPEC.
- TO CONFORM TO SINGATRON HAZARDOUS SUBSTANCE FREE SPEC.
- HALOGEN FREE PRODUCT IDENTIFICATION MARK : ☉
- HALOGEN FREE PRODUCT IDENTIFICATION LABEL ON PACKAGING:
- FOR REFLOW SOLDERING LEAD-FREE PROCESS.
- PACKAGING : TAPE & REEL.

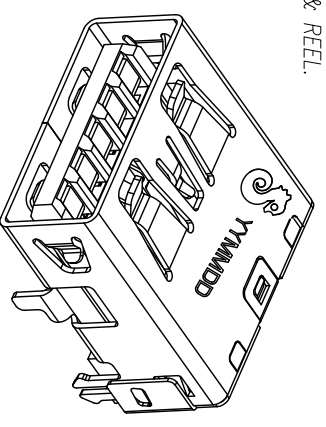

F	REAR SHELL	1	SPCC 0.20t	NICKEL 60U" MIN
E	4P TERMINAL	4	COOPER ALLOY 0.25t	GOLD 2u" OVER Pd/Ni 300" ON CONTACT AREA
D	5P TERMINAL	5	COOPER ALLOY 0.25t	IN 120u" ON SOLDER TAIL, ALL OVER 80U" NICKEL PLATED
C	SHELL	1	STAINLESS STEEL	NICKEL 60U" MIN
B	HOUSING	1	HIGH TEMPERATURE	BLACK
A	BASE	1	HIGH TEMPERATURE	BLACK
NO	DESCRIPTION	QTY	MATERIAL	PLATING & COLOR
UNLESS OTHERWISE SPECIFIED TOLERANCES				
DECIMALS: ANGLES:				
X	: ±0.5	X	: ±2°	
XX	: ±0.3	XX	: ±1°	
XXX	: ±0.2			
Singatron Enterprise Co., Ltd. 信晉企業股份有限公司				
TITLE: USB3.0 REVERSE CONNECTOR				
DMW	DATE: 13/5/20	PART NO.:	ZUB4004-000101	
CHKD	DATE: 13/5/20	SCALE:	4:1	UNIT: mm
APVD	DATE: 13/5/20	SIZE:	A3	SHEET: 1 OF 1
CUSTOMER COPY				