

REV.	ECN NO OR DESCRIPTION	REVISED	DATE
A	PDR NO:T140923-5B	Edi.Zhou	2015.01.13
B	ECN NO:S150459-C	PENG	2015.04.16

SPECIFICATIONS:

- ELECTRICAL CHARACTERISTICS:**
 - CURRENT RATING: 1.8A (PIN1,4) ; OTHER CONTACTS 0.25A
 - CONTACT RESISTANCE: 30mΩ MAX.
 - DIELECTRIC WITHSTANDING VOLTAGE: 100V AC FOR 1 MINUTE
 - INSULATION RESISTANCE: 100MΩ MIN
- MECHANICAL CHARACTERISTICS:**
 - INSERTION FORCE : 3.5 Kgf MAX
 - WITHDRAWAL FORCE : 1.0 Kgf MIN ,0.8 Kgf(AFTER TEST)
- DURABILITY: 5,000 CYCLES.**
- TO CONFORM TO SINGATRON HAZARDOUS SUBSTANCE FREE SPEC.**
- HALOGEN FREE PRODUCT IDENTIFICATION MARK ON JACK: ©**
- HALOGEN FREE PRODUCT IDENTIFICATION LABEL ON PACKAGING:** 
- FOR IR - REFLOW PROCESS.**
- DATE : YYMMDD**
- PACKAGING : TAPE & REEL.**

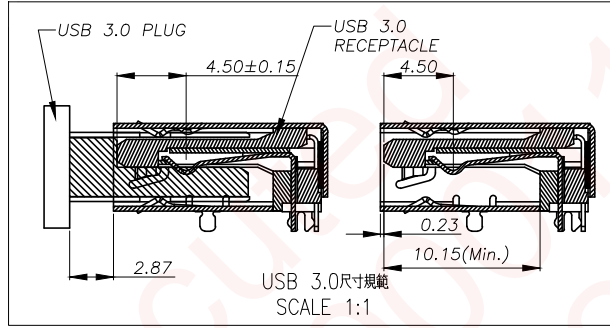

USB 3.0尺寸規範
SCALE 1:1

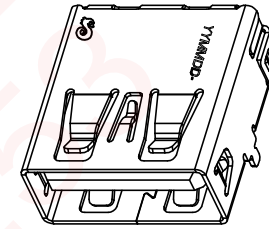

3D VIEW

Pin Number	Signal ASSIGNMENT
PIN 1	VBUS
PIN 2	D-
PIN 3	D+
PIN 4	GND
PIN 5	StdA_SSRX-
PIN 6	StdA_SSRX+
PIN 7	GND_DRAIN
PIN 8	StdA_SSTX-
PIN 9	StdA_SSTX+

F	MYLAR	1		
E	TERMINAL	5	COOPER ALLOY T=0.25mm	Au 30µin PLATED ON MATING AREA, Matte Sn 100µ PLATED ON SOLDERING 80µ NICKEL UNDER PLATING OVERALL
D	TERMINAL	4	COOPER ALLOY T=0.25mm	Au 30µin PLATED ON MATING AREA, Matte Sn 100µ PLATED ON SOLDERING 80µ NICKEL UNDER PLATING OVERALL
C	SHELL	1	STAINLESS STEEL	NICKEL 60µ"MIN
B	BASE	1	PA-9T UL94V-0	BLACK
A	HOUSING	1	PA-9T UL94V-0	BLACK
NO	DESCRIPTION	QTY	MATERIAL	PLATING & COLOR

UNLESS OTHERWISE SPECIFIED TOLERANCES		Singatron Enterprise Co., Ltd. 信音企業股份有限公司		
DECIMALS: ANGLES:		TITLE: USB 3.0 CONNECTOR		
X :±0.50	X :±2°	DWN	PENG	PART NO.2UB4006-360201F
X.X :±0.30	X.X :±1°	CHKD	CERRY	SCALE 1:1 UNIT: mm
X.XX :±0.25		APVD	LIAO	SIZE: A3 SHEET:1 OF 1 REV:B
CUSTOMER COPY				

