

REV. A	ECN NO OR DESCRIPTION	REVISED	DATE
	PRODUCT RELEASE	Acheng	2012.07.26

SPECIFICATIONS:

- ELECTRICAL CHARACTERISTICS:**
 - 1-1. CURRENT RATING: 1.8A (PIN1, 4) ; OTHER CONTACTS 0.25A
 - 1-2. CONTACT RESISTANCE: 30mΩ MAX.
 - 1-3. DIELECTRIC WITHSTANDING VOLTAGE: 100V AC FOR 1 MINUTE
 - 1-4. INSULATION RESISTANCE: 100M ΩMIN
- MECHANICAL CHARACTERISTICS:**
 - 2-1. INSERTION FORCE : 3.5 kgf MAX
 - 2-2. WITHDRAWAL FORCE : 1.0 kgf MIN(INITIAL),0.8 kgf MIN(AFTER TEST)
- DURABILITY:** 5,000 CYCLES.
- TO CONFORM TO SINGATRON HAZARDOUS SUBSTANCE FREE SPEC.**
- HALOGEN PRODUCT IDENTIFICATION MARK ON JACK: ©**
- HALOGEN PRODUCT IDENTIFICATION LABEL ON PACKAGING:** 
- FOR WAVE SOLDERING LEAD-FREE PROCESS.**
- DATE : YM/M/DD**
- PACKAGING : TAPE & REEL.**

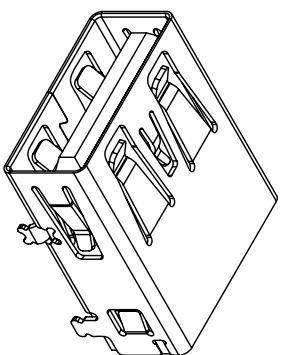
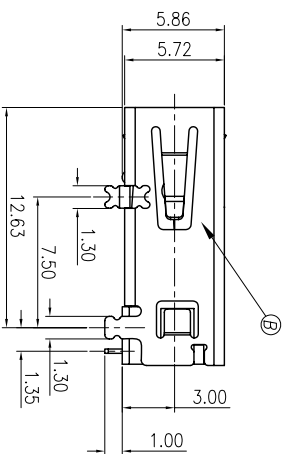
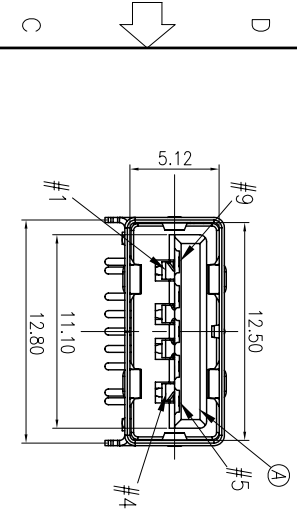
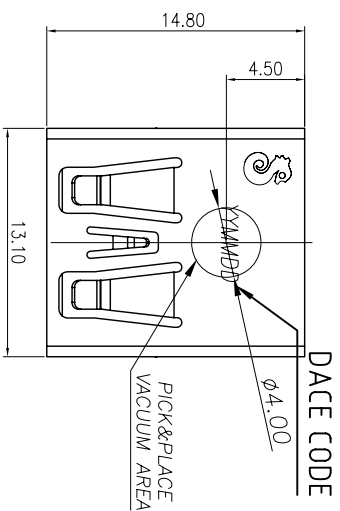

Pin Number	Signal ASSIGNMENT
PIN 1	VBUS
PIN 2	D-
PIN 3	D+
PIN 4	GND
PIN 5	StDA_SSRX-
PIN 6	StDA_SSRX+
PIN 7	GND_DRAIN
PIN 8	StDA_SSTX-
PIN 9	StDA_SSTX+

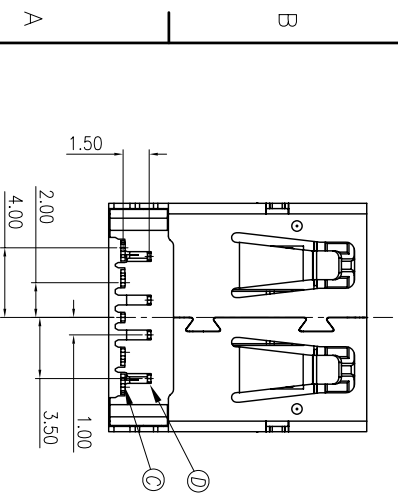
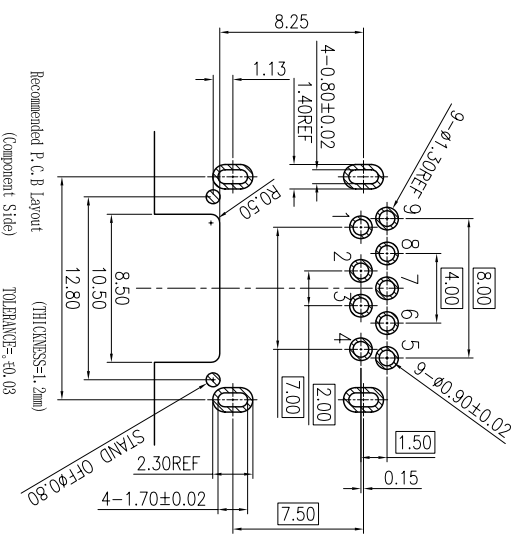

D	4P TERMINAL	4	COPPER ALLOY	GOOD FLASH ON MATING AREA, MATE TIL 1000° ON SOLDER AREA, 500 NICKEL UNDER PLATING OVERALL
C	5P TERMINAL	5	COPPER ALLOY	
B	SHELL	1	SUS 0.30T	NICKEL 60U" MIN
A	HOUSING	1	HIGH TEMPERATURE MATERIAL	BLUE(300C)
NO	DESCRIPTION	QTY	MATERIAL	PLATING & COLOR

UNLESS OTHERWISE SPECIFIED TOLERANCES

 Singatron Enterprise Co., Ltd.
信亨企業股份有限公司

TITLE	USB 3.0 CONNECTOR
DWNN	KACHING
CHKD	EMH
APVD	ANGELA 2012.8.3
PART NO.	2UB4013-600101P
SCALE	1:1
UNIT	mm
SIZE	A3
SHEET	1 OF 1
REV.	A

CUSTOMER COPY