

Recommended P.C.B Layout (THICKNESS=1.2mm)
(Component Side) TOLERANCE=±0.03

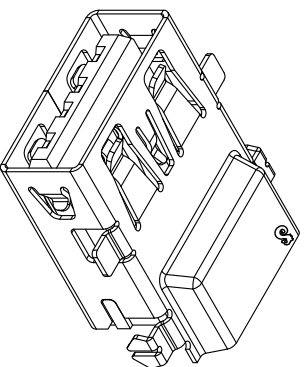
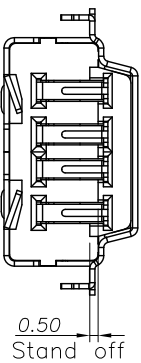
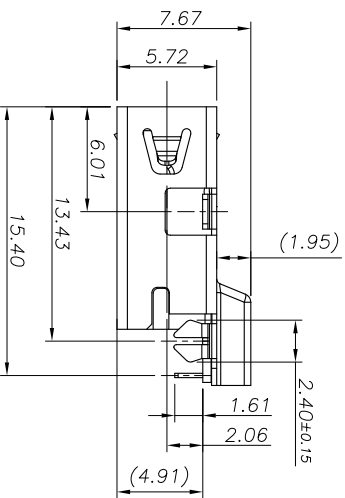
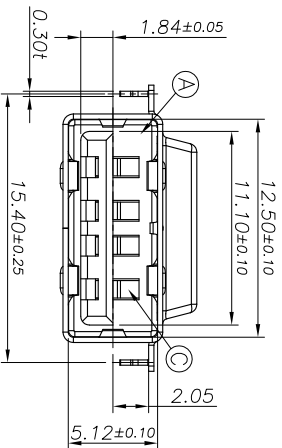

REV.	ECN NO. OR DESCRIPTION	REVISED	DATE
A	PRODUCT RELEASE	VICTOR	2011.10.04
B	ECN NO. : T110071	Geor	2011.12.29
C	ECN NO. : T120017	Victor	2012.05.02
D	ECN NO. : S141021	SEAN	2014.12.04

SPECIFICATIONS:

- ELECTRICAL CHARACTERISTICS:
 - CONTACT RESISTANCE: 30mΩ maximum when measured at 20mV maximum open circuit at 100mA
 - DIELECTRIC WITHSTANDING VOLTAGE: The dielectric must withstand 500V AC Max With 1 Minute
 - INSULATION RESISTANCE: 1000MΩ minimum
 - CURRENT RATING: 1.5A at 250V AC minimum when measured at an ambient temperature of 25° C
- MECHANICAL CHARACTERISTICS:
 - INSERTION FORCE: 3.5 Kgf MAX
 - WITHDRAWAL FORCE: 1.0 Kgf MIN
- TO CONFORM TO SINGATRON HAZARDOUS SUBSTANCE FREE SPEC.
- HALOGEN FREE PRODUCT IDENTIFICATION MARK ON JACK:
- HALOGEN FREE PRODUCT IDENTIFICATION LABEL ON PACKAGING:
- FOR IR RE-FLOW PROCESS.
- DATE : YMMDD
- PACKAGING : TAPE & REEL.

C	TERMINAL	4	COPPER ALLOY	20%Ni OVER 30%Pd/Ni PLATED ON MATING AREA, 120μ" Sn PLATED ON SOLDERING 80%NICKEL UNDER PLATING OVERALL
B	SHELL	1	STAINLESS STEEL	NICKEL 60μ"MIN
A	HOUSING	1	LCP UL94V-0	BLACK
NO	DESCRIPTION	QTY	MATERIAL	PLATING & COLOR

UNLESS OTHERWISE SPECIFIED TOLERANCES
 Singatron Enterprise Co., Ltd.
 信音企業股份有限公司

TITLE : USB 2.0 REVERSE CONNECTOR

DECIMALS:	ANGLES:
X : ±0.5	X : ±2°
X.X : ±0.3	X.X : ±1'
X.XX : ±0.2	

DWN	SEAN	PART NO.2UB4015-000111
CHKD	CERRY	SCALE 1:1 UNIT: mm
APVD	LAO	SIZE: A3 SHEET: 1 OF 1 REV: D

CUSTOMER COPY

A B C D E F

1

2

3

4

5

6

7

8