

SPECIFICATIONS:

- ELECTRICAL CHARACTERISTICS:
 - CURRENT RATING: 1.8A (PIN1,4) ; OTHER CONTACTS 0.25A
 - CONTACT RESISTANCE: 30mΩ MAX.
 - DIELECTRIC WITHSTANDING VOLTAGE: 100V AC FOR 1 MINUTE
 - INSULATION RESISTANCE: 100MΩ MIN 100VDC FOR 2 MINUTES
- MECHANICAL CHARACTERISTICS:
 - INSERTION FORCE : 3.5 Kgf MAX
 - WITHDRAWAL FORCE : 1.0 Kgf MIN
- DURABILITY: 5,000 CYCLES.
- TO CONFORM TO SINGATRON HAZARDOUS SUBSTANCE FREE SPEC.
- HALOGEN FREE PRODUCT IDENTIFICATION MARK ON JACKS.Ⓢ
- HALOGEN FREE PRODUCT IDENTIFICATION LABEL ON PACKAGING.Ⓢ
- FOR WAVE SOLDERING LEAD-FREE PROCESS.
- DATE : YMMDD
- PACKAGING : TAPE & REEL.

| REV. | ECN NO OR DESCRIPTION | REVISED | DATE |
|------|-----------------------|---------|------------|
| A | PRODUCT RELEASE | Acheng | 2012.01.31 |
| B | ECN NO: S130121 | SEAN | 2013.05.13 |
| C | ECN NO: S121223 | ANGUS | 2013.06.10 |

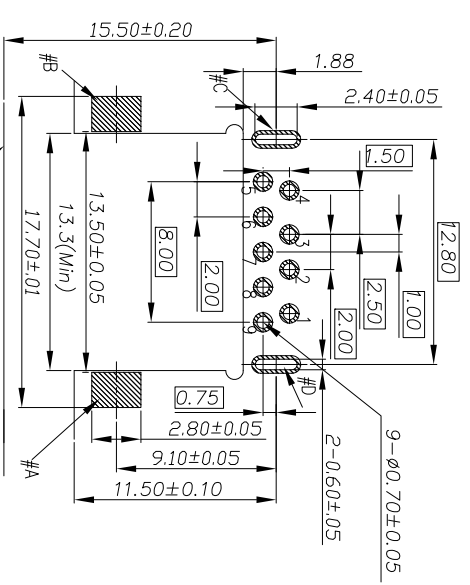
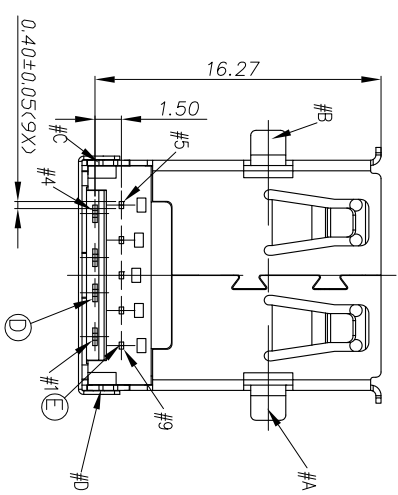

| NO | DESCRIPTION | QTY | MATERIAL | PLATING & COLOR |
|----|-------------|-----|-----------------|---|
| F | REAR SHELL | 1 | STAINLESS STEEL | |
| E | TERMINAL | 5 | COPPER ALLOY | S/P+30u"Ti/P/NI PLATED ON MATING AREA/SURF0u" PLATED ON SOLDERING 50u" NICKEL UNDER PLATING OVERALL |
| D | TERMINAL | 4 | PHOSPHOR BRONZE | S/P+30u"Ti/P/NI PLATED ON MATING AREA/SURF0u" PLATED ON SOLDERING 50u" NICKEL UNDER PLATING OVERALL |
| C | SHELL | 1 | STAINLESS STEEL | NICKEL 60u" |
| B | BASE | 1 | THERMOPLASTIC | BLUE (300C) |
| A | COVER | 1 | THERMOPLASTIC | BLUE (300C) |

UNLESS OTHERWISE SPECIFIED TOLERANCES

| DECIMALS: | ANGLES: |
|-------------|-----------|
| X : ±0.5 | X : ±2° |
| X.X : ±0.3 | X.X : ±1' |
| X.XX : ±0.2 | |

Singatron Enterprise Co., Ltd.
信亨企業股份有限公司

TITLE USB 3.0 REVERSE CONNECTOR

DWN ANGUS PART NO. 2UB4016-150101F

CHKD CERRY SCALE 1:1 UNIT: mm

APVD MAX SIZE: A3 SHEET: 1 OF 1 REV: C

CUSTOMER COPY