

REV. ECN NO OR DESCRIPTION	REVISED	DATE
A PRODUCT RELEASE	VICTOR	2012.01.06

- SPECIFICATIONS:
- ELECTRICAL CHARACTERISTICS:
 - CURRENT RATING: 1.8A (PIN1,4) ; OTHER CONTACTS 0.25A
 - CONTACT RESISTANCE: 30mΩ MAX.
 - DIELECTRIC WITHSTANDING VOLTAGE: 100V AC FOR 1 MINUTE
 - INSULATION RESISTANCE: 100M Ω MIN
 - MECHANICAL CHARACTERISTICS:
 - INSERTION FORCE : 3.5 Kgf MAX
 - WITHDRAWAL FORCE : 1.0 Kgf(INITIAL),0.8 Kgf(AFTER TEST)
 - DURABILITY: 5,000 CYCLES.
 - TO CONFORM TO SINGATRON HAZARDOUS SUBSTANCE FREE SPEC.
 - HALOGEN PRODUCT IDENTIFICATION MARK ON JACK: ©
 - FOR WAVE SOLDERING LEAD-FREE PROCESS.
 - DATE : YM/M/DD
 - PACKAGING : TAPE & REEL.

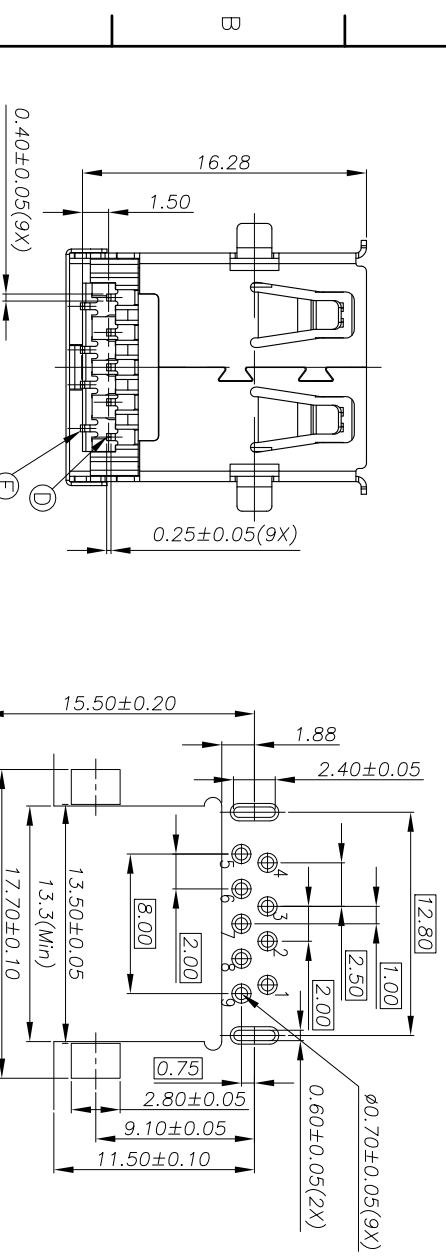
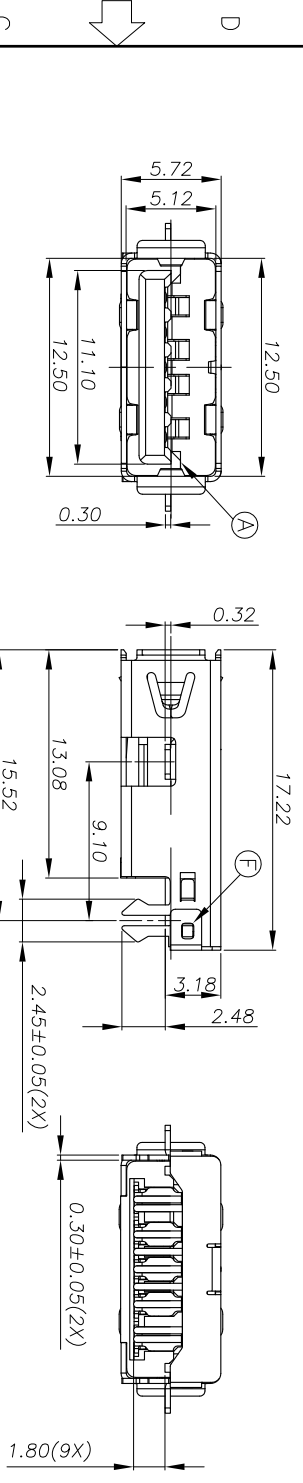
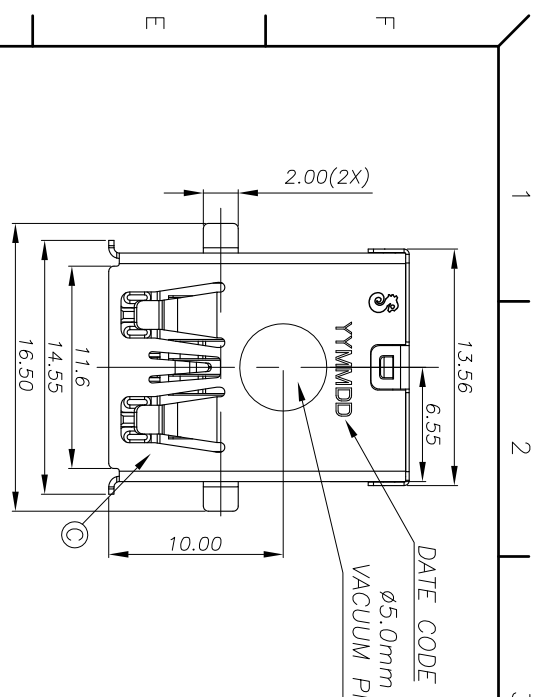
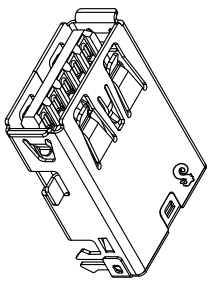

CONNECTOR FRONT EDGE

Recommended P.C.B Layout

NO	DESCRIPTION	QTY	MATERIAL	PLATING & COLOR
F	REAR SHELL	1	STAINLESS STEEL	
E	TERMINAL	5	COPPER ALLOY	2.2µm OVER 30µm/Pd/Ni PLATED ON MATING AREA, 120µm Sn PLATED ON SOLDERING 80µm NICKEL UNDER PLATING OVERALL
D	TERMINAL	4	COPPER ALLOY	2.2µm OVER 30µm/Pd/Ni PLATED ON MATING AREA, 120µm Sn PLATED ON SOLDERING 80µm NICKEL UNDER PLATING OVERALL
C	SHELL	1	STAINLESS STEEL	NICKEL 60µm MIN
B	BASE	1	THERMOPLASTIC 94-V0	BLUE (300C)
A	COVER	1	THERMOPLASTIC 94-V0	BLUE (300C)
	UNLESS OTHERWISE SPECIFIED TOLERANCES			

DECIMALS: ANGLES:

X : ±0.5 X : ±2°
 X.X : ±0.3 X.X : ±1°
 X.XX : ±0.2

TITLE: USB 3.0 REVERSE CONNECTOR

DWN: *Victor* PART NO. 2UB34016-700101F

CHKD: SCALE 1:1 UNIT: mm

APVD: *Victor* 1/10-12 SIZE: A3 SHEET: 1 OF 1 REV: A

CUSTOMER COPY

Singatron Enterprise Co., Ltd.
 信音企業股份有限公司