

REV.	ECN NO OR DESCRIPTION	REVISED	DATE
A	PRODUCE RELEASE	JIANGUO	2011.01.07
B	ECN:C120013Modify body	Longqiang	2012.01.19

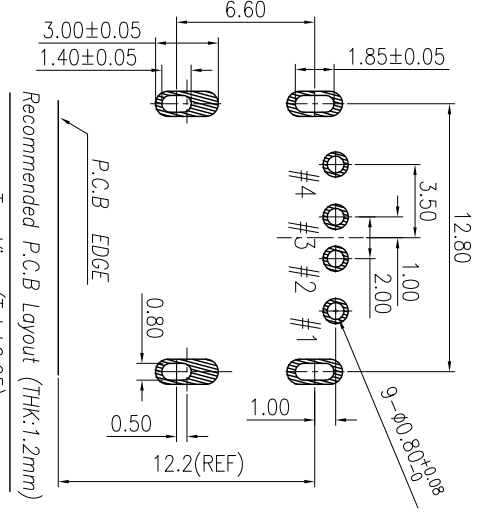
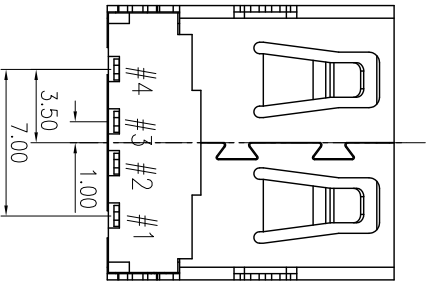
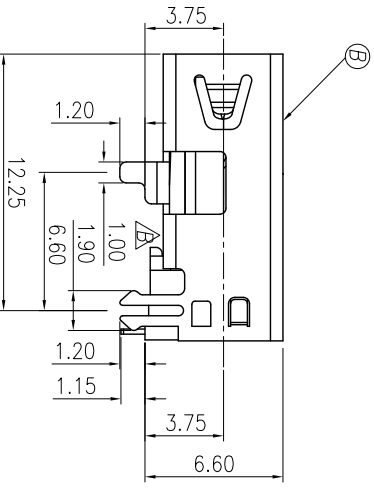
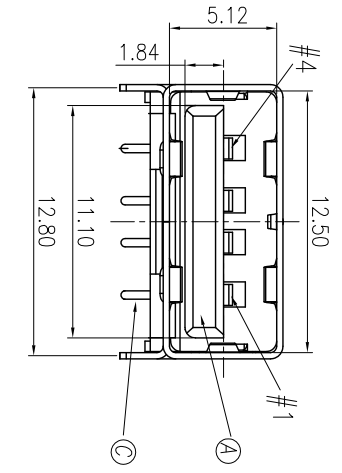
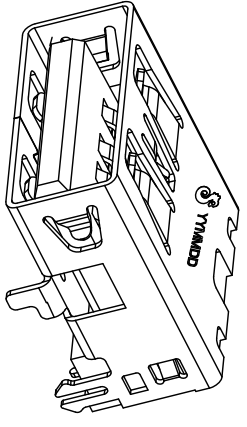
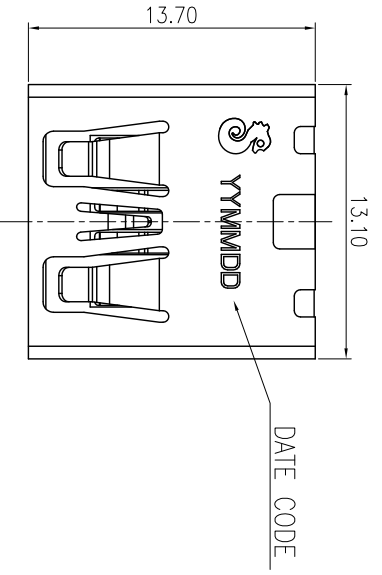

SPECIFICATIONS:

- ELECTRICAL CHARACTERISTICS:**
 - CURRENT RATING: 1.8A (PIN1,4) ; OTHER CONTACTS 0.25A
 - CONTACT RESISTANCE: 30mΩ MAX.
 - DIELECTRIC WITHSTANDING VOLTAGE: 500V AC FOR 1 MINUTE
 - INSULATION RESISTANCE: 100MΩ MIN
- MECHANICAL CHARACTERISTICS:**
 - INSERTION FORCE : 35N MAX
 - WITHDRAWAL FORCE : 8N MIN
- DURABILITY:** 1500 CYCLES.
- TO CONFORM TO SINGATRON HAZARDOUS SUBSTANCE FREE SPEC.**
- HALOGEN FREE PRODUCT IDENTIFICATION MARK IN JACK:**
- HALOGEN FREE PRODUCT IDENTIFICATION LABEL ON PACKAGING:**
- FOR REFLOW SOLDERING LEAD-FREE PROCESS.**
- PACKAGING :** TAPE & REEL.

- PACKAGING: TAPE&REEL
- COLOR: BLACK
- PLATING

C	TERMINAL	4	PHOSPHOR BRONZE	GOLD FLASH
B	SHELL	1	SUS	NICKEL PLATED
A	HOUSING	1	THERMOPLASTIC	BLACK
NO	DESCRIPTION	QTY	MATERIAL	PLATING & COLOR

UNLESS OTHERWISE SPECIFIED TOLERANCES

Singatron Enterprise Co., Ltd.
信音企业股份有限公司

DECIMALS:	ANGLES:
X : ±0.5	X : ±2°
X.X : ±0.3	X.X : ±1'
X.XX : ±0.2	

TITLE	USB2.0 REVERSE CONNECTOR
DWN	Partion 2012/01/19
CHKD	2012/01/19
APVD	2012/01/19
UNIT:	mm
SCALE:	4:1
SIZE:	A3
SHEET:	10F1
REV.:	B

CUSTOMER COPY