

REV.	ECN NO.	OR DESCRIPTION	REVISED	DATE
A	PDR NO.:1170726-4A	penq		2017.09.19
B	ECN NO.:S202008-C17	LAJUN		2020.11.05

DATE CODE

0.45 MAX(2X)

0.75 MAX(4X)

SPECIFICATIONS:

1. ELECTRICAL CHARACTERISTICS:

1-1. CURRENT RATING: 5V 3.0A

1-2. CONTACT RESISTANCE: 30mΩ Max.

1-3. DIELECTRIC WITHSTANDING VOLTAGE: 500V AC FOR 1 MINUTE

1-4. INSULATION RESISTANCE: 1000MΩ Min.

1-5. CONTACT CAPACITANCE: 2 pF Max.

2. MECHANICAL CHARACTERISTICS:

2-1. INSERTION FORCE : 35N Max.

2-2. WITHDRAWAL FORCE : 10N Min.

3. DURABILITY: 5000 CYCLES.

4. OTHER SPEC TO REFER 2UB4022 SERIES SPEC.

5. TO CONFORM TO SINGATRON HAZARDOUS SUBSTANCE FREE SPEC.

6. HALOGEN FREE PRODUCT IDENTIFICATION MARK : 

7. HALOGEN FREE PRODUCT IDENTIFICATION LABEL ON PACKAGING:

8. FOR REFLOW SOLDERING. LEAD-FREE PROCESS.

9. PACKAGING : TAPE & REEL.

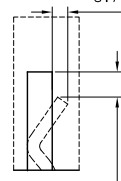
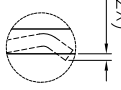

Detail B
PLUG In

Detail A
Spring Motion
Highest Point

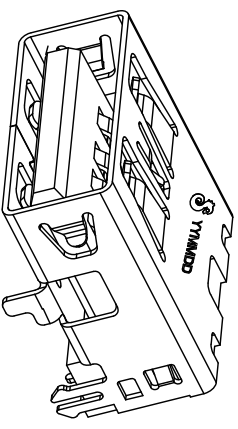
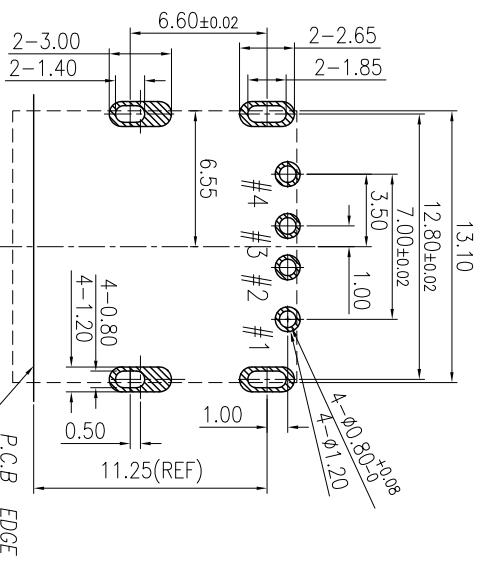
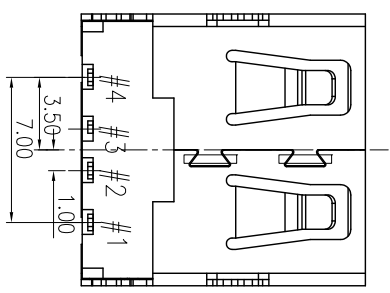
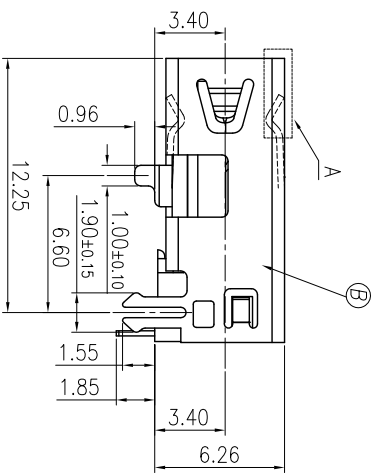
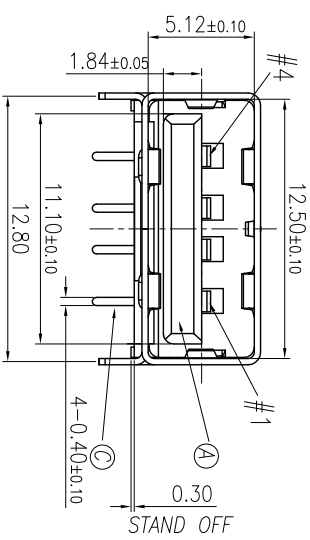
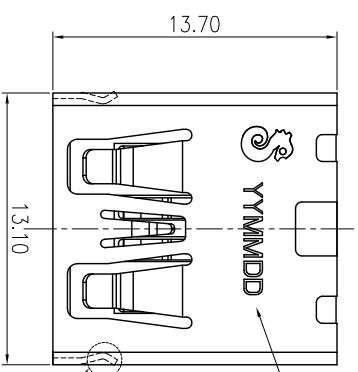

C	TERMINAL	4	COPPER ALLOY 0.25T	ON CONTACT AREA, ON SOLDER TAIL, MATE TIN 120U, ON SOLDER TAIL, ALL OVER 80U NICKEL PLATED
B	SHELL	1	STAINLESS STEEL 0.3T	NICKEL PLATED
A	HOUSING	1	PA9T UL94-V0	BLACK
NO	DESCRIPTION	QTY	MATERIAL	PLATING & COLOR
UNLESS OTHERWISE SPECIFIED TOLERANCES				
 Singatron Enterprise Co., Ltd. 信晉企業股份有限公司				
DECIMALS: ANGLES:				
X	:±0.5	X	:±2°	
X,X	:±0.3	X,X	:±1°	
X,XX	:±0.2			

Recommended P.C.B Layout
Top View (To:±0.05)

TITLE				
DWN	LAJUN	PART NO.	2UB4022-001151F	
CHKD	imes	SCALE	4:1	UNIT: mm
APVD	bove	SIZE:	A3	SHEET: 10F1
REV: B				
CUSTOMER COPY				

