

REV.	ECN NO OR DESCRIPTION	REVISED	DATE
A	NEW RELEASE	ZW	2012.03.22
B	ECN NO.:L202310-P01	Ye wei	2023.10.26

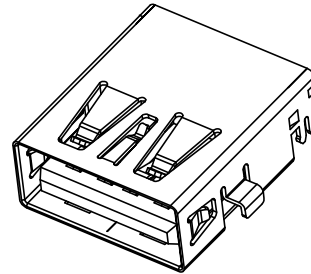
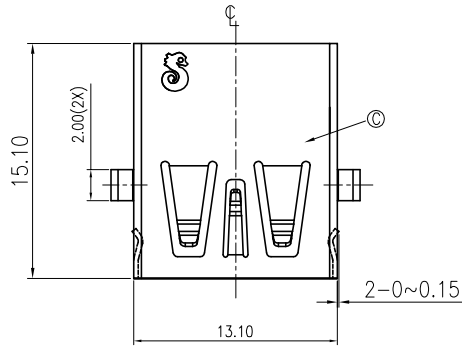

SPECIFICATIONS:

1. ELECTRICAL CHARACTERISTICS:

- 1-1. CURRENT RATING: 2.0A (PIN1,4) ; OTHER CONTACTS 0.25A
- 1-2. CONTACT RESISTANCE: 30mΩ MAX.
- 1-3. DIELECTRIC WITHSTANDING VOLTAGE: 500V AC FOR 1 MINUTE
- 1-4. INSULATION RESISTANCE: 100MΩ MIN

2. MECHANICAL CHARACTERISTICS:

- 2-1. INSERTION FORCE : 3.5 Kgf MAX
- 2-2. WITHDRAWAL FORCE : 1.0 Kgf MIN

3. DURABILITY: 5,000 CYCLES.

4. TO CONFORM TO SINGATRON HAZARDOUS SUBSTANCE FREE SPEC.

5. OTHER GENERAL SPEC. TO REFER "2UB4023 SERIES SPEC"

6. HALOGEN FREE PRODUCT IDENTIFICATION LABEL ON PACKAGING:



7. FOR REFLOW SOLDERING LEAD-FREE PROCESS.

8. PACKAGE: TAPE&REEL

9. PRODUCT NO: 2UB4023-0 0 0 1 1 F

HOUSING MATERIAL	0 0 0 1 1 F	HALOGEN FREE
CONTACT PLATING	0 0 0 1 1 F	PACKAGE TYPE
DURABILITY	0 0 0 1 1 F	USB TYPE
		1=TAPE&REEL
		1=5000 CYCLES
		1=USB 2.0 TYPE

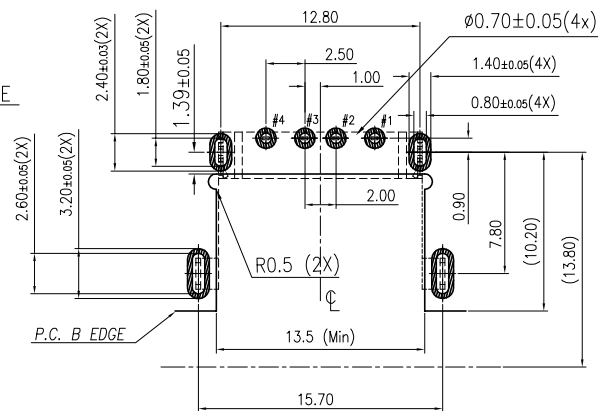
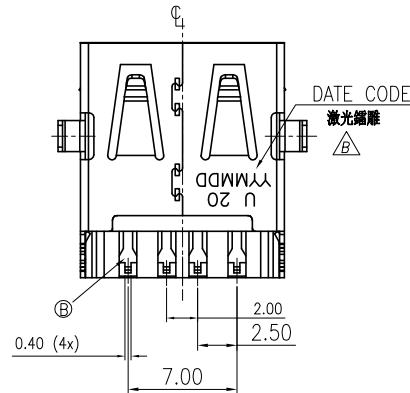
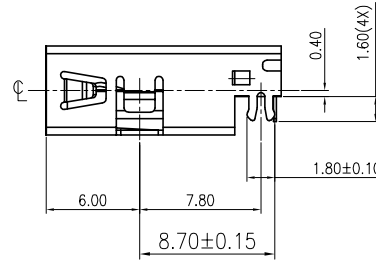
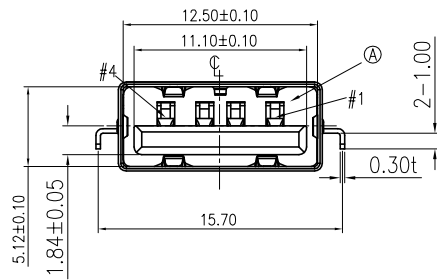

Recommended P.C.B Layout (THK:1.0mm)
Top View (Tol:±0.05)

C	SHELL	1	STEEL	NICKEL PLATED
B	TERMINAL	4	COPPER ALLOY	GOLD FLASH PLATED ON CONTACT AREA SN PLATED ON SOLDER TAIL, ALL OVER NI PLATED
A	HOUSING	1	HIGH TEMP PLASTIC THERMOPLASTIC UL94-V0	BLACK
NO	DESCRIPTION	QTY	MATERIAL	PLATING & COLOR
UNLESS OTHERWISE SPECIFIED TOLERANCES				
Singatron Enterprise Co., Ltd. 信音企業股份有限公司				
DECIMALS:		TITLE		
X	:±0.5	X	:±2°	
X.X	:±0.3	X.X	:±1°	
X.XX	:±0.2			
		DWN	Ye wei	
		CHKD	Jim-deng	
		APVD	Jim-deng	
		TITLE		
		USB2.0 DIP A TYPE FEMALE, PH=0.40mm		
		PART NO. 2UB4023-000111F		
		SCALE	3:1	
		UNIT:	mm	
		SIZE:	A3	
		SHEET:	1 OF 1	
		REV:	B	
CUSTOMER COPY				