

REV.	ECN NO OR DESCRIPTION	REVISED	DATE
A	INITIAL RELEASE	LY	2013.10.24

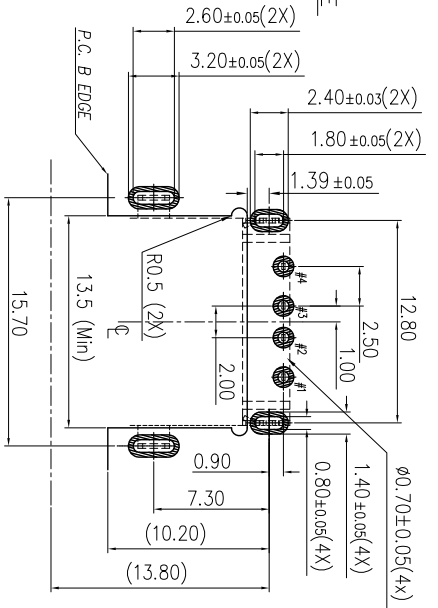

Recommended P.C.B Layout (Thk:1.0mm)
Top View (Tol:±0.05)

- SPECIFICATIONS:
- ELECTRICAL CHARACTERISTICS:
 - CURRENT RATING: 2.0A (PIN1,4) ; OTHER CONTACTS 0.25A
 - CONTACT RESISTANCE: 30mΩ MAX.
 - DIELECTRIC WITHSTANDING VOLTAGE: 500V AC FOR 1 MINUTE
 - INSULATION RESISTANCE: 100MΩ MIN
 - MECHANICAL CHARACTERISTICS:
 - INSERTION FORCE : 3.5 Kgf MAX
 - WITHDRAWAL FORCE : 1.0 Kgf MIN
 - DURABILITY: 5,000 CYCLES.
 - TO CONFORM TO SINGATRON HAZARDOUS SUBSTANCE FREE SPEC.
 - OTHER GENERAL SPEC. TO REFER "SUB2YXX SERIES SPEC"
 - HALOGEN FREE PRODUCT IDENTIFICATION LABEL ON PACKAGING.
 - FOR REFLOW SOLDERING LEAD-FREE PROCESS.
 - PACKAGE: TAPE&REEL

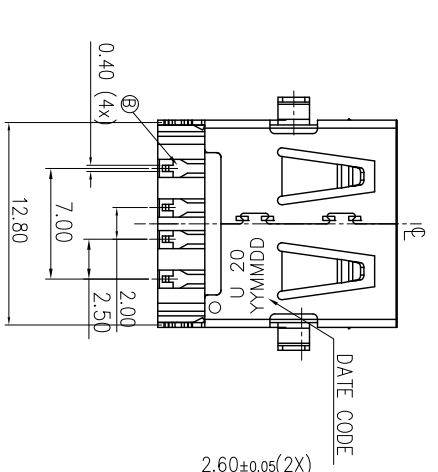
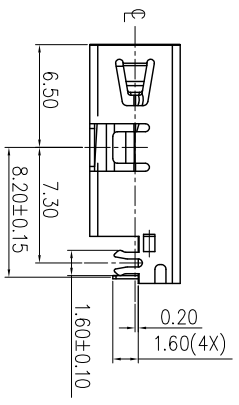
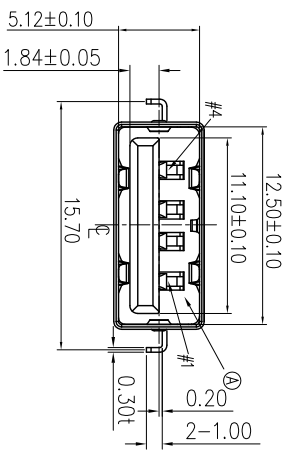
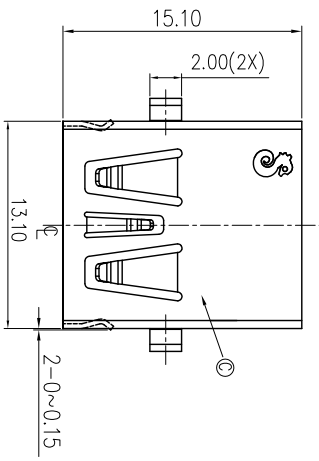
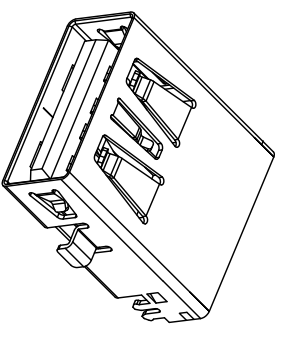

C	SHELL	1	SUS304	NICKEL 50μ" Min-PLATED
B	TERMINAL	4	C5191	SOLD FLASH PLATED ON CONTACT AREA, 50μm Min PLATED ON SOLDER TAIL, THE OTHER IN 30μm Min PLATED
A	HOUSING	1	LCP ul94-V0	BLACK
NO	DESCRIPTION	QTY	MATERIAL	PLATING & COLOR
UNLESS OTHERWISE SPECIFIED TOLERANCES				
Singatron Enterprise Co., Ltd. 信亨企業股份有限公司				
TITLE: USB2.0 DIP A TYPE FEMALE, PH=0.20mm				
DECIMALS:	ANGLES:			
X : ±0.5	X : ±2°			
X.X : ±0.3	X.X : ±1°			
X.XX : ±0.2				

DWN	LY	PART NO.	ZUB4023-000611F
CHKD	KIM	SCALE 1:1	UNIT: mm
APVD	SEAN	SIZE: A3	SHEET: 10F1
REV. A			
CUSTOMER COPY			

