

REV.	ECN NO OR DESCRIPTION	REVISED	DATE
A	PDR RELEASE	IVY-C	2015.02.03

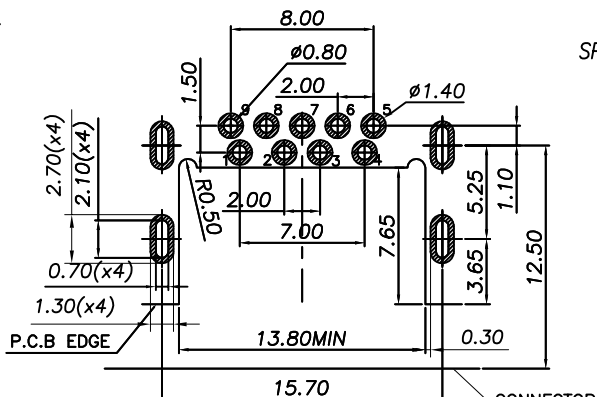
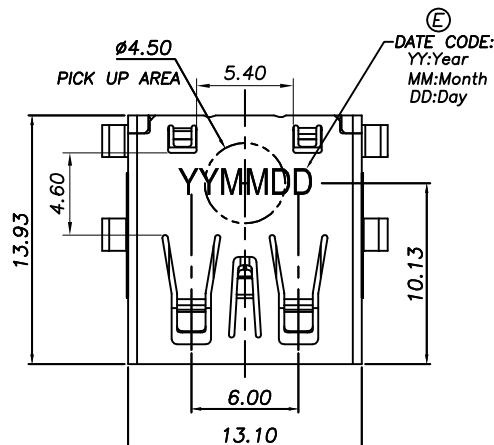

RECOMMENDED P.C.B PATTERN LAYOUT
TOLERANCE ±0.05mm T=1.20±0.05

SPECIFICATIONS:

- ELECTRICAL CHARACTERISTICS:
 - CURRENT RATING: 1.8A (PIN1,4), THE OTHER CONTACTS 0.25A MIN.
 - CONTACT RESISTANCE: 30mΩ MAX.
 - INSULATION RESISTANCE: 100MΩ MIN.
 - DIELECTRIC WITHSTANDING VOLTAGE: 100V AC FOR 1 MINUTE.
- MECHANICAL CHARACTERISTICS:
 - INSERTION FORCE: 35N MAX.
 - WITHDRAWAL FORCE: 10N~25N(INITIAL), AND 8N~25N MIN. AFTER TEST.
- LIFE TEST: 5,000 CYCLES.
- TEMPERATURE RANGE: -25°C TO +85°C.
- OTHER GENERAL SPEC. TO REFER "2UB4032-000211F SPEC".
- TO CONFORM TO THE SINGATRON HAZARDOUS SUBSTANCE FREE SPEC.
- HALOGEN FREE PRODUCT IDENTIFICATION LABEL ON PACKAGING:
- PACKAGE: SEE "2UB4032-000211F PACKAGE".
- FOR REFLOW SOLDERING LEAD-FREE PROCESS.

PART NO.

2UB4032-000211F

- SUFFIX: HALOGEN FREE
- PACKAGE: 1: TAPE & REEL
- HOUSING COLOR: 1: BLACK
- CONTACT PLATING: 2: GOLD FLASH ON CONTACT AREA, 100u" Sn PLATING ON SOLDER AREA, 50u" Ni UNDERPLATING OVERALL

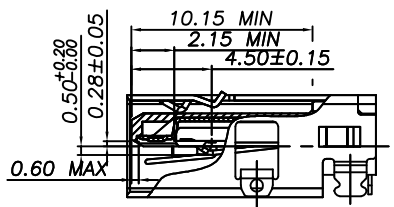
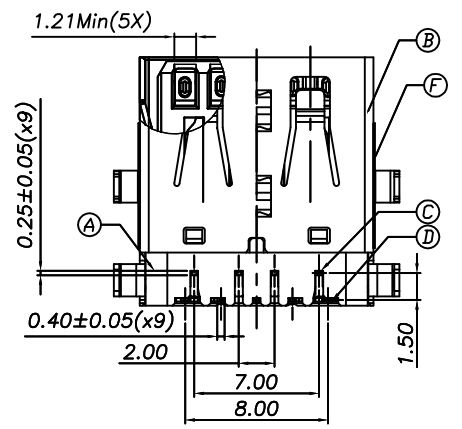
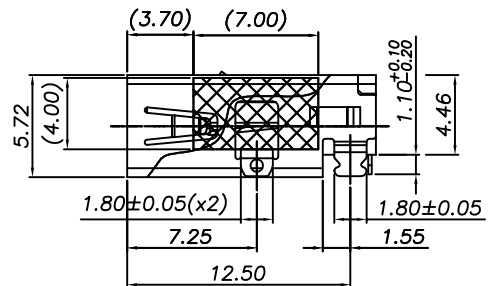
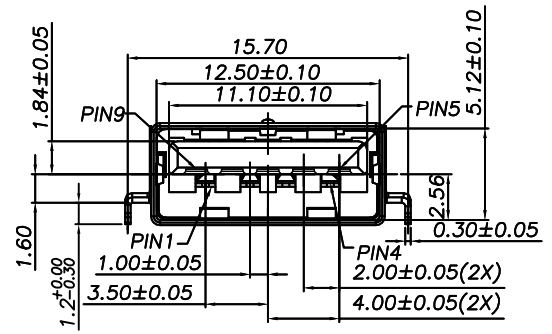

F	MYLAR	2		
E	INK			BLACK
D	CONTACT (3.0)	5	C2680R-H, 0.20t	SEE PART NO.
C	CONTACT (2.0)	4	C2680R-H, 0.25t	SEE PART NO.
B	SHELL	1	SUS201, 0.30t	NICKEL PLATED
A	HOUSING	1	LCP6130L, UL 94V-0	BLACK
NO	DESCRIPTION	QTY	MATERIAL	PLATING & COLOR

UNLESS OTHERWISE SPECIFIED TOLERANCES		Singatron Enterprise Co., Ltd. 信音企業股份有限公司	
DECIMALS:	ANGLES:	TITLE	USB 3.0 A TYPE FEMALE, R/A, DIP, SINKING
X : ±0.5	X : ±2°	DWN	IV-C 2015.02.03 PART NO. 2UB4032-000211F
XX : ±0.3	XX : ±1°	CHKD	ANGELA 2015.02.03 SCALE 1:1 UNIT: mm
XXX : ±0.2		APVD	ANGELA 2015.02.03 SIZE: A3 SHEET: 1 OF 1 REV: A
CUSTOMER COPY			