

- SPECIFICATIONS:**
- 1. ELECTRICAL CHARACTERISTICS:**
- 1-1. CURRENT RATING: 1.8A (PIN1,4) ; OTHER CONTACTS 0.25A
 - 1-2. CONTACT RESISTANCE: 30mΩ MAX.
 - 1-3. DIELECTRIC WITHSTANDING VOLTAGE: 100V AC FOR 1 MINUTE
 - 1-4. INSULATION RESISTANCE: 100MΩ/MIN.
- 2. MECHANICAL CHARACTERISTICS:**
- 2-1. INSERTION FORCE : 3.5 Kgf MAX
 - 2-2. WITHDRAWAL FORCE : 1.0 kgf(INITIAL),0.8 kgf(AFTER TEST)
 - 3. DURABILITY: 5,000 CYCLES.
 - 4. TO CONFORM TO SINGATRON HAZARDOUS SUBSTANCE FREE SPEC.
 - 5. HALOGEN FREE IDENTIFICATION MARK ON JACK. ©
 - 6. HALOGEN FREE IDENTIFICATION LABEL ON PACKAGING. ©
 - 7. FOR IR - REFLOW LEAD-FREE PROCESS.
 - 8. DATE : YYMMDD
 - 9. PACKAGING : TAPE & REEL.

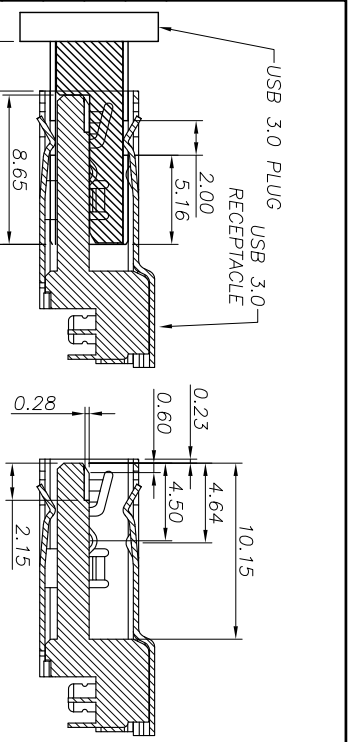
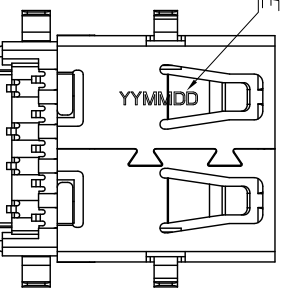
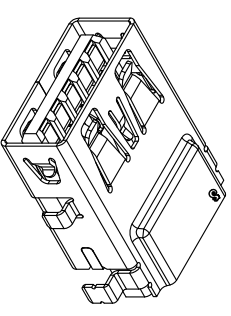

Pin Number	Signal ASSIGNMENT	Pin Number	Signal ASSIGNMENT
PIN 5	SHdL_SSRX-	PIN 1	VBUS
PIN 6	SHdL_SSRX+	PIN 2	D-
PIN 7	GND_DRAIN	PIN 3	D+
PIN 8	SHdL_SSRX-	PIN 4	GND
PIN 9	SHdL_SSRX+		

E	TERMINAL	5	COOPER ALLOY	GOLD FLASH PLATED ON MATING AREA Wet. Sn 100% MIN PLATED ON SOLDERING 60% NICKEL UNDER PLATING OVERALL
D	TERMINAL	4	COOPER ALLOY	
C	SHELL	1	STAINLESS STEEL	NICKEL 60U"MIN
B	BASE	1	HIGH THERMOPLASTIC	BLUE (300C)
A	HOUSING	1	HIGH THERMOPLASTIC	BLUE (300C)
NO	DESCRIPTION		MATERIAL	PLATING & COLOR

UNLESS OTHERWISE SPECIFIED TOLERANCES

DECIMALS: ANGLES:

X :±0.5 X :±2°

X.X :±0.3 X.X :±1°

X.XX :±0.2



Singatron Enterprise Co., Ltd.
信亨企業股份有限公司

TITLE	USB 3.0 REVERSE CONNECTOR
DWN	SEAN PART NO.2UB4037-000101F
CHKD	CERRY SCALE 1:1 UNIT: mm
APVD	LUSSEN SIZE: A3 SHEET: 1 OF 1 REV: B

CUSTOMER COPY