

|      |                       |         |            |
|------|-----------------------|---------|------------|
| REV. | ECN NO OR DESCRIPTION | REVISED | DATE       |
| A    | PDR No:T150916-5A     | TOMMY   | 2016.03.14 |

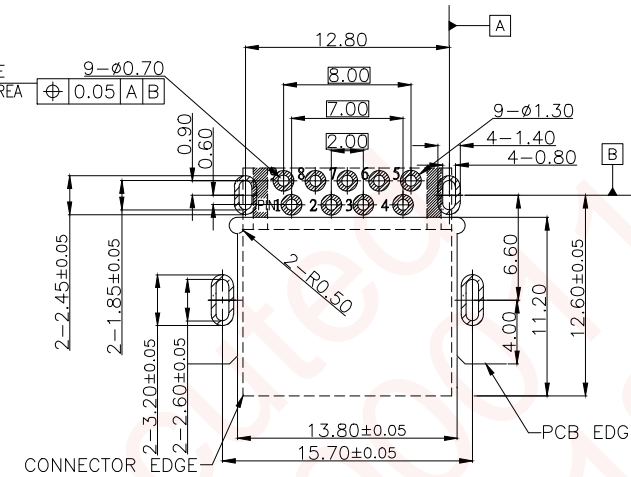

Recommended P.C.B Layout(TOP VIEW)  
(THK:1.0mm) TOLERANCE=±0.03

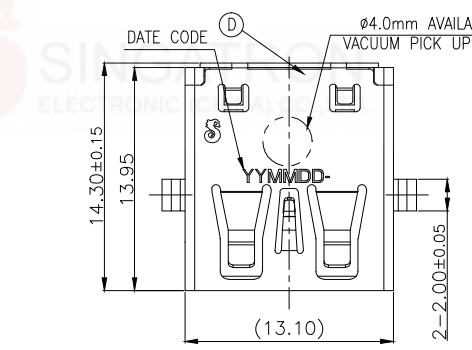
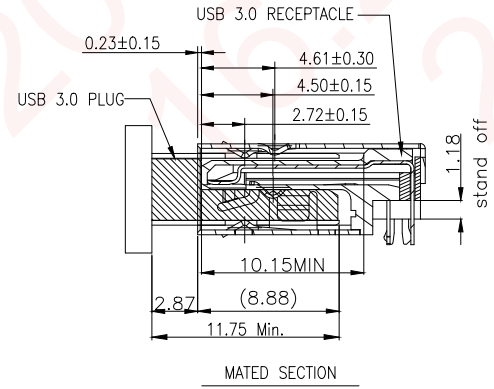
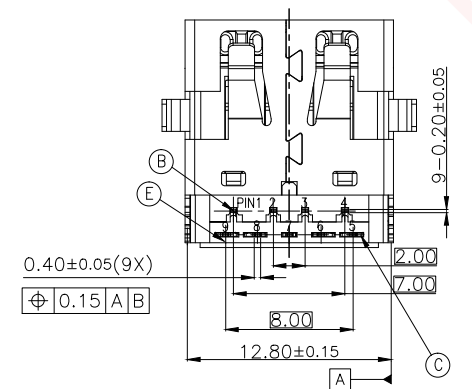
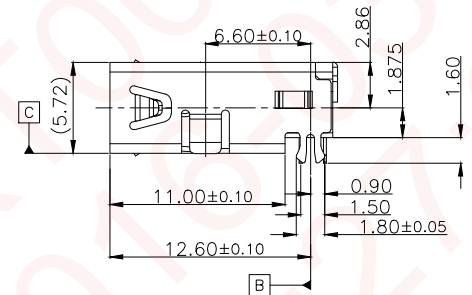
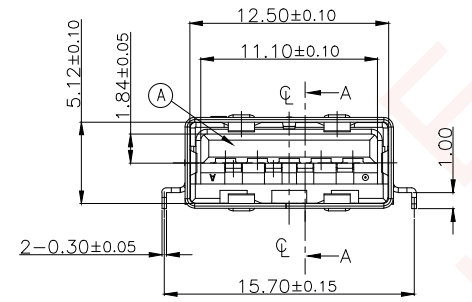

SPECIFICATIONS:

- ELECTRICAL CHARACTERISTICS:
  - CURRENT RATING: 1.8A (PIN1,4) ; OTHER CONTACTS 0.25A
  - CONTACT RESISTANCE: 30mΩ MAX INITIAL FOR PIN 1-4.  
50mΩ MAX INITIAL FOR OTHER PIN.
  - DIELECTRIC WITHSTANDING VOLTAGE: 100V AC FOR 1 MINUTE
  - INSULATION RESISTANCE: 100MΩ MIN .
- MECHANICAL CHARACTERISTICS:
  - INSERTION FORCE : 3.5 Kgf MAX.
  - WITHDRAWAL FORCE : 1.0 Kgf MIN(INITIAL),0.8 Kgf(AFTER TEST)
- DURABILITY: 5,000 CYCLES.
- TO CONFORM TO SINGATRON HAZARDOUS SUBSTANCE FREE SPEC.
- HALOGEN FREE IDENTIFICATION MARK ON JACK:
- HALOGEN FREE IDENTIFICATION LABEL ON PACKAGING:
- FOR IR REFLOW PROCESS.
- DATE : YYMMDD-
- PACKAGING : TAPE & REEL

| REMARK             | Pin Number | SIGNAL ASSIGNMENT |
|--------------------|------------|-------------------|
| USB2.0 CONTACT PIN | PIN 1      | VBUS              |
|                    | PIN 2      | D-                |
|                    | PIN 3      | D+                |
|                    | PIN 4      | GND               |
| USB3.0 CONTACT PIN | PIN 5      | StdA_SSRX-        |
|                    | PIN 6      | StdA_SSRX+        |
|                    | PIN 7      | GND_DRAIN         |
|                    | PIN 8      | StdA_SSTX-        |
|                    | PIN 9      | StdA_SSTX+        |

| NO | DESCRIPTION    | QTY | MATERIAL            | PLATING & COLOR  |
|----|----------------|-----|---------------------|--|
| E  | CAP            | 1   | PA-4T+30%GF(TX1)    | BLACK  |
| D  | SHELL          | 1   | SUS304 1/2H, T=0.30 | NICKEL 60uin MIN   |
| C  | 5 PIN TERMINAL | 5   | C2680-H ,T=0.20     | Au 2uin OVER 30uin Pd/Ni PLATED ON CONTACT AREA;<br>Matte Sn 120uin PLATED ON SOLDERING ALL OVER 80uin NICKEL PLATING. |
| B  | 4 PIN TERMINAL | 4   | C5210-EH ,T=0.20    |  |
| A  | BODY           | 1   | PA-4T+30%GF(TX1)    | BLACK  |

| NO                                    | DESCRIPTION | QTY  | MATERIAL  | PLATING & COLOR                   |
|---------------------------------------|-------------|--|-----------|-----------------------------------|
| UNLESS OTHERWISE SPECIFIED TOLERANCES |             | Singatron Enterprise Co., Ltd.<br>信音企業股份有限公司 |           |                                   |
| DECIMALS:                             |             | TITLE  |           |                                   |
| X                                     | :±0.5       | X  | :±2°      | USB 3.0 STD CONNECTOR             |
| X.X                                   | :±0.3       | X.X  | :±1°      | DWN TOMMY PART NO:2UB4044-500101F |
| X.XX                                  | :±0.2       | CHKD   | SCALE:4:1 | UNIT: mm                          |
|                                       |             | APVD   | SIZE: A3  | SHEET:1 OF 1 REV:A                |
| CUSTOMER COPY                         |             |  |           |                                   |