

- SPECIFICATIONS:**
- ELECTRICAL CHARACTERISTICS:**
    - CURRENT RATING: 1.8A (PIN1,4) ; OTHER CONTACTS 0.25A
    - CONTACT RESISTANCE: 30mΩ MAX.
    - DIELECTRIC WITHSTANDING VOLTAGE: 100V AC FOR 1 MINUTE
    - INSULATION RESISTANCE: 100MΩ MIN
  - MECHANICAL CHARACTERISTICS:**
    - INSERTION FORCE : 3.5 Kgf MAX
    - WITHDRAWAL FORCE : 1.0 kgf MIN(INITIAL),0.8kgf MIN(AFTER TEST)
  - DURABILITY: 5,000 CYCLES.
  - TO CONFORM TO SINGATRON HAZARDOUS SUBSTANCE FREE SPEC.
  - HALOGEN PRODUCT IDENTIFICATION MARK ON JACK: ©
  - HALOGEN PRODUCT IDENTIFICATION LABEL ON PACKAGING: 
  - FOR IR REFLOW PROCESS.
  - DATE : YMMDD
  - PACKAGING : TAPE & REEL

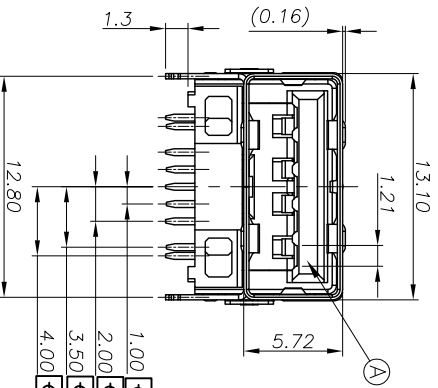

1.00	Φ 0.2	A	B
2.00	Φ 0.2	A	B
3.50	Φ 0.2	A	B
4.00	Φ 0.2	A	B

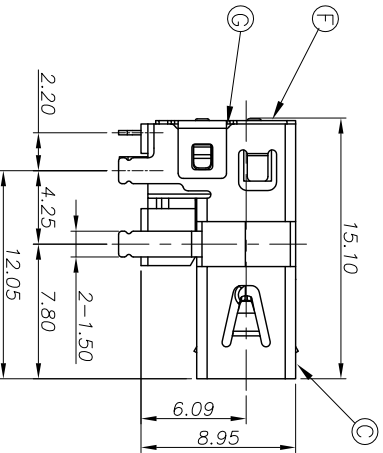
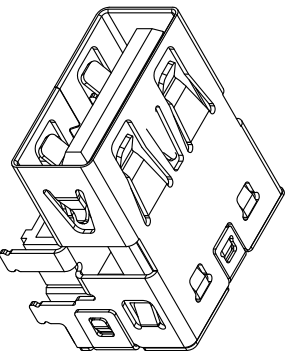
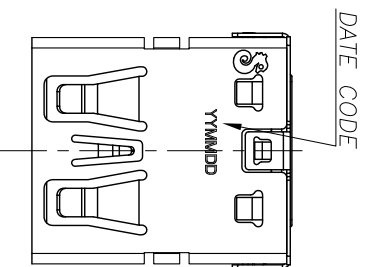
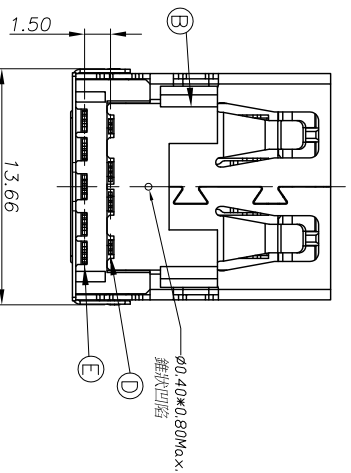
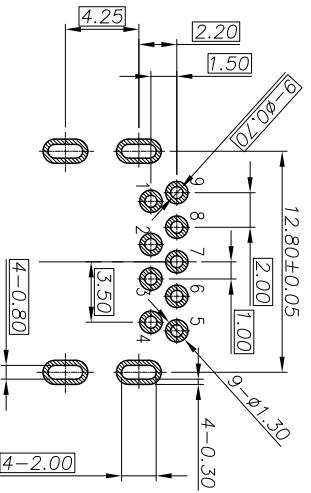
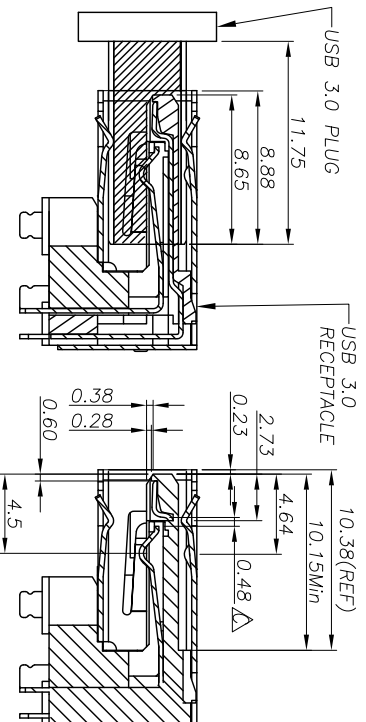

Recommended P.C.B Layout  
(Component Side)

REV.	ECN NO	OR DESCRIPTION	REVISED	DATE
A		PRODUCT RELEASE	Acheng	2012.04.20
B		ECN NO : T120052	GEAR	2012.06.19
Δ		ECN NO : T120109	Acheng	2012.10.29

G	MYLAR	1	KAPTON	
F	SHELL COVER	1	SUS	
E	TERMINAL	5	BRASS	
D	TERMINAL	4	PHOSPHOR BRONZE	GOLD FLASH ON WATING AREA WATE TIN PLATED ON SOLDERING NICKEL UNDER PLATING OVERALL
C	SHELL	1	SUS	NICKEL
B	BASE	1	PA9T	BLUE
A	HOUSING	1	PA9T	BLUE
NO	DESCRIPTION	QTY	MATERIAL	PLATING & COLOR

UNLESS OTHERWISE SPECIFIED TOLERANCES

Singatron Enterprise Co., Ltd.  
信亨企業股份有限公司

TITLE	DECIMALS:	ANGLES:
USB 3.0 CONNECTOR	±0.5	X ±2°
	±0.3	X.X ±1°
	±0.2	X.XX

CUSTOMER COPY

A

B

C

D

E

F

1

2

3

4

5

6

7

8

F

A

B

C

D

E

F

1

2

3

4

5

6

7

8

文#機# RD-06-043-A