

REV.	ECN NO OR DESCRIPTION	REVISED	DATE
A	ECN NO:S131205	Ken	2014.04.17
B	ECN NO:S140766	SEAN	2014.09.12

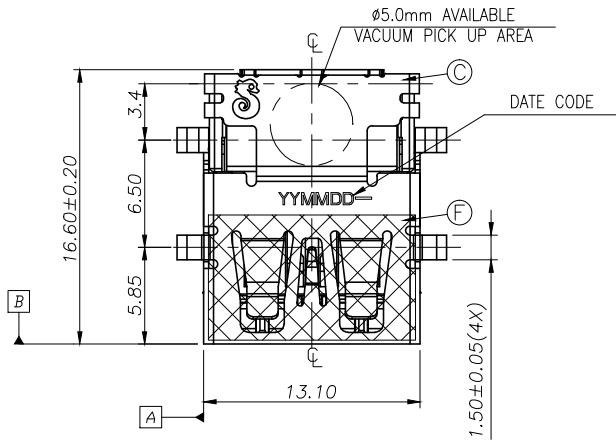

SPECIFICATIONS:

- ELECTRICAL CHARACTERISTICS:**
 - CURRENT RATING: 1.8A (PIN1,4) ; OTHER CONTACTS 0.25A
 - CONTACT RESISTANCE: 30mΩ MAX.
 - DIELECTRIC WITHSTANDING VOLTAGE: 100V AC FOR 1 MINUTE
 - INSULATION RESISTANCE: 100MΩ MIN
- MECHANICAL CHARACTERISTICS:**
 - INSERTION FORCE : 3.5 Kgf MAX
 - WITHDRAWAL FORCE : 1.0 Kgf MIN(INITIAL),0.8 Kgf(AFTER TEST)
- DURABILITY:** 5,000 CYCLES.
- TO CONFORM TO SINGATRON HAZARDOUS SUBSTANCE FREE SPEC.
- HALOGEN FREE PRODUCT IDENTIFICATION MARK ON JACK: Ⓢ
- HALOGEN FREE PRODUCT IDENTIFICATION LABEL ON PACKAGING: Ⓢ
- FOR IR REFLOW PROCESS.
- DATE : YYMMDD-
- PACKAGING : TAPE & REEL.

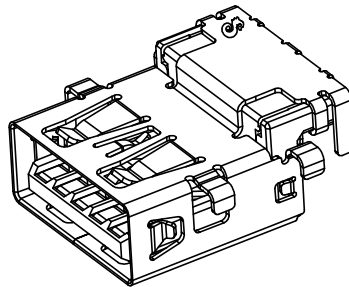
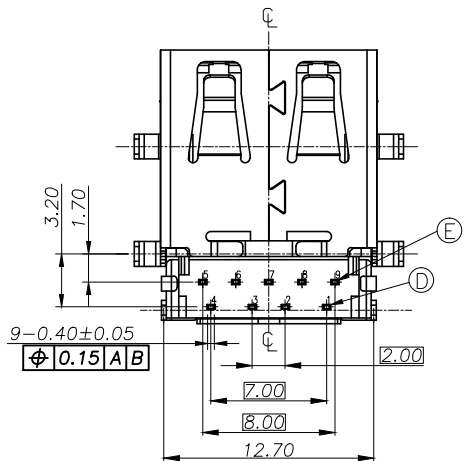
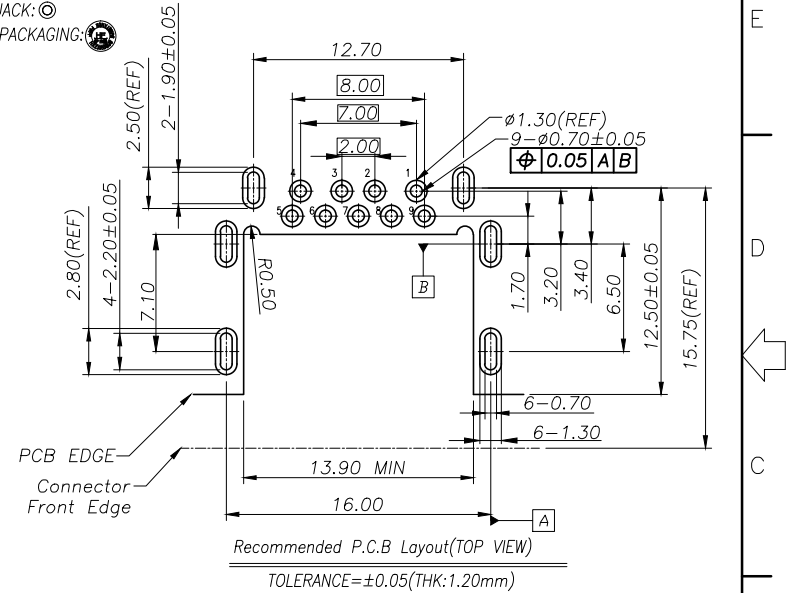
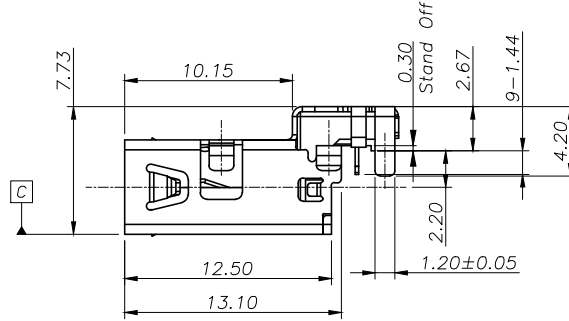
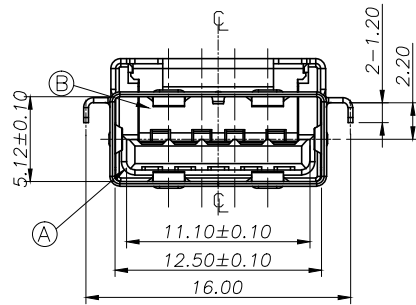

Pin	Signal NAME	DESCRIPTION	QTY	MATERIAL	PLATING & COLOR
	F	MYLAR	1	11.0mm*8.0mm	YELLOW
	E	5-TERMINAL	5	C2680 ,T=0.20	2μin Au+30μin Pb/Ni ON MATING AREA, MATTE Sn 120μin ON SOLDERING AREA, 80μin NICKEL UNDER PLATING OVERALL
	D	4-TERMINAL	4	C5210 ,T=0.20	
	C	SHELL	1	STAINLESS STEEL T=0.30	NICKEL 60μin MIN
	B	BASE	1	PA-9T UL94V-0	BLACK
	A	HOUSING	1	PA-9T UL94V-0	BLACK
	NO	DESCRIPTION	QTY	MATERIAL	PLATING & COLOR
1	VBUS				
2	D-				
3	D+				
4	GND				
5	StdA_SSRX-				
6	StdA_SSRX+				
7	GND_DRAIN				
8	StdA_SSTX-				
9	StdA_SSTX+				

UNLESS OTHERWISE SPECIFIED TOLERANCES

Singatron Enterprise Co., Ltd.
信音企業股份有限公司

TITLE: USB 3.0 REVERSE CONNECTOR
DWN: SEAN PART NO.2UB4054-100101F
CHKD: CERRY SCALE 1:1 UNIT: mm
APVD: LUSSEN SIZE: A3 SHEET:1 OF 1 REV:B

CUSTOMER COPY