

| REV. | ECN NO OR DESCRIPTION | REVISED | DATE |
|------|------------------------|---------|------------|
| B | ECN NO:S140461 | SEAN | 2014.09.01 |
| C | ECN NO:S150136/S150221 | SEAN | 2015.03.20 |
| D | ECN NO:S150646-E | PENG | 2015.08.31 |

ø4.5mm AVAILABLE VACUUM PICK UP AREA

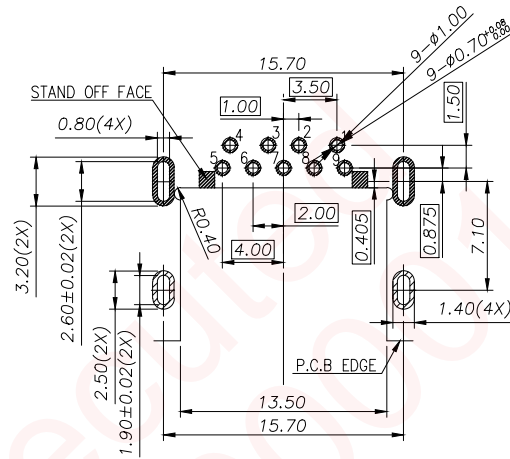
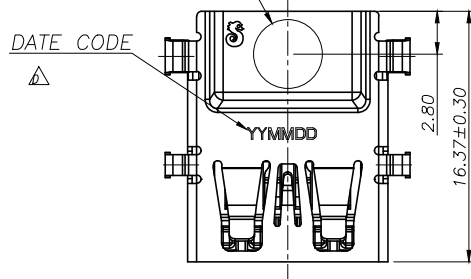

SPECIFICATIONS:

- ELECTRICAL CHARACTERISTICS:**
 - CURRENT RATING: 1.8A (PIN1,4) ; OTHER CONTACTS 0.25A
 - CONTACT RESISTANCE: 30mΩ MAX.
 - DIELECTRIC WITHSTANDING VOLTAGE: 100V AC FOR 1 MINUTE
 - INSULATION RESISTANCE: 100MΩ MIN
- MECHANICAL CHARACTERISTICS:**
 - INSERTION FORCE : 3.5 Kgf MAX
 - WITHDRAWAL FORCE : 1.0~2.2Kgf (INITIAL),0.8~2.2Kgf (AFTER TEST)
- DURABILITY:** 5,000 CYCLES.
- TO CONFORM TO SINGATRON HAZARDOUS SUBSTANCE FREE SPEC.
- HALOGEN FREE IDENTIFICATION MARK ON JACK: Ⓞ
- HALOGEN FREE IDENTIFICATION LABEL ON PACKAGING:
- FOR IR REFLOW PROCESS.
- DATE : YYMMDD-
- PACKAGING : TAPE & REEL.

Recommended P.C.B Layout (THICKNESS=1.2mm)
(Component Side) TOLERANCE=±0.03 TOP VIEW

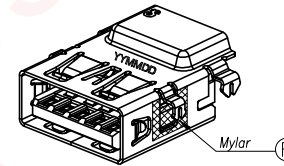
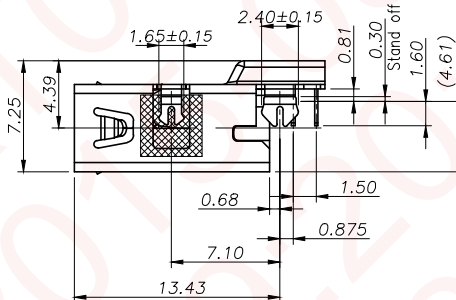
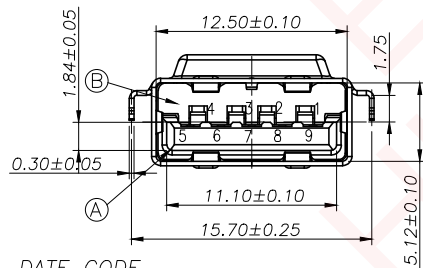

| Pin Number | Signal NAME |
|------------|-------------|
| 1 | VBUS |
| 2 | D- |
| 3 | D+ |
| 4 | GND |
| 5 | StdA_SSRX- |
| 6 | StdA_SSRX+ |
| 7 | GND_DRAIN |
| 8 | StdA_SSTX- |
| 9 | StdA_SSTX+ |

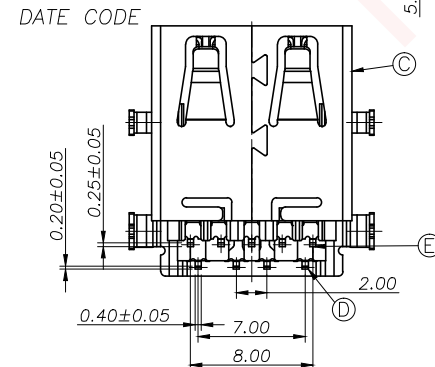

| | | | | |
|----|-------------|-----|----------------|---|
| F | MYLAR | 2 | KAPTON 4.0*4.0 | |
| E | TERMINAL | 5 | C2680 T0.25 | 2µin Au+30µin Pd/Ni PLATED ON MATING AREA,120µin MATTE Sn PLATED ON SOLDERING |
| D | TERMINAL | 4 | C5210 T0.20 | 80µin NICKEL UNDER PLATING OVERALL |
| C | SHELL | 1 | SUS304 T0.30 | NICKEL 60µin MIN |
| B | BASE | 1 | PA4T UL94V-0 | BLACK |
| A | HOUSING | 1 | PA4T UL94V-0 | BLACK |
| NO | DESCRIPTION | QTY | MATERIAL | PLATING & COLOR |

| | | | | |
|---------------------------------------|----------|--|-------|------------------------------------|
| UNLESS OTHERWISE SPECIFIED TOLERANCES | | Singatron Enterprise Co., Ltd. 信音企業股份有限公司 | | |
| DECIMALS: | ANGLES: | TITLE | | |
| X :±0.5 | X :±2° | USB 3.0 REVERSE CONNECTOR | | |
| X.X :±0.3 | X.X :±1° | DWN | PENG | PART NO.2UB4055-100101F |
| X.XX :±0.2 | | CHKD | CERRY | SCALE 1:1 UNIT: mm |
| | | APVD | LIAO | SIZE: A3 SHEET:1 OF 1 REV:D |
| CUSTOMER COPY | | | | |