

1 2 3 4 5 6 7 8

F
E
D
C
B
A

F
E
D
C
B
A

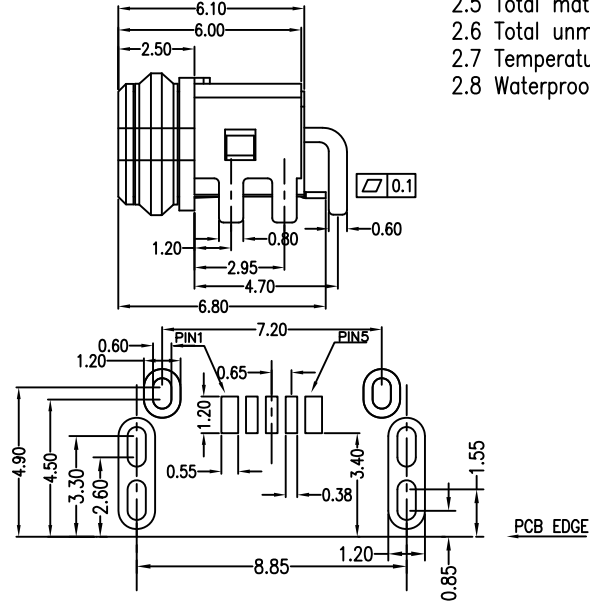
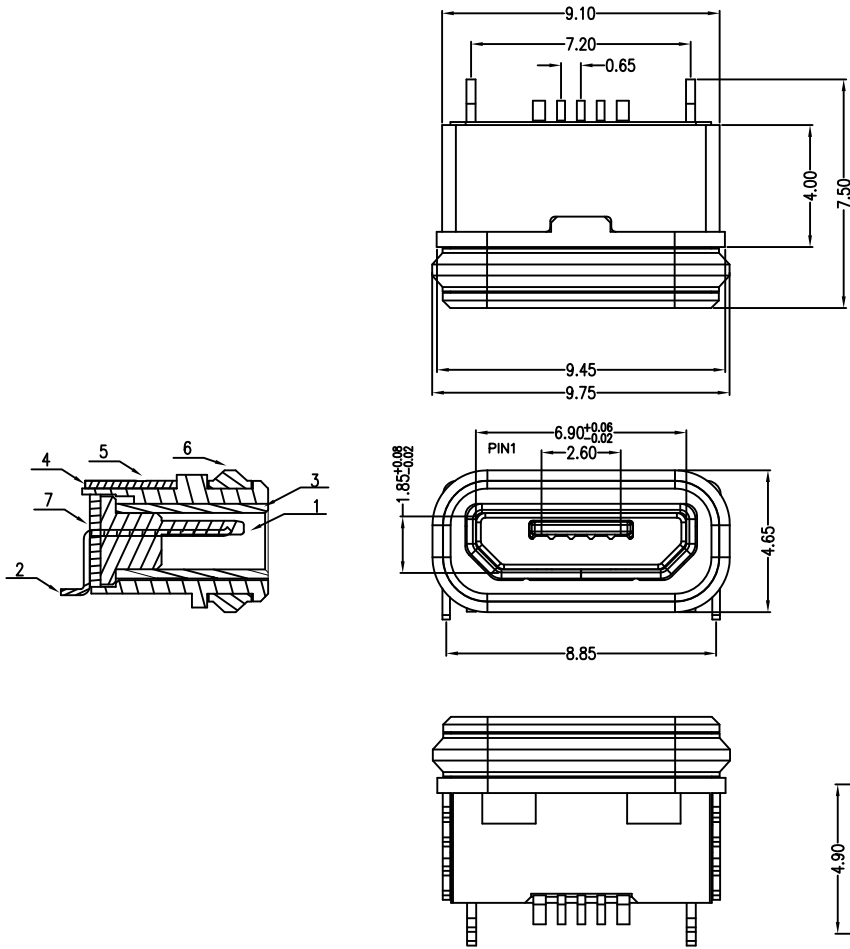

RECOMMEND PCB LAYOUT

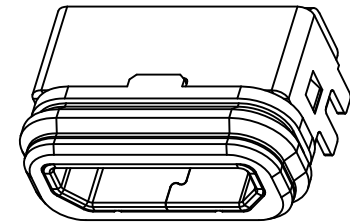

Note:

1.Material:

- 1.1 Housing: LCP, Black
- 1.2 Contact: Copper alloy, t=0.20mm, Au 1u"
- 1.3 Shell: SUS304, t=0.30mm, Matte Tin
- 1.4 Cover: LCP, Black
- 1.5 Out Shell: SUS304 t=0.25, Matte Tin
- 1.6 Ring: SILICON
- 1.7 Epoxy: Epoxy

2.Specification:

- 2.1 Current rating:1,5PIN 2.0A Max/2,3,4PIN 1A Max.
- 2.2 Dielectric withstanding voltage: 100 V(ac) for 1 min.
- 2.3 Contact resistance: 30 mΩ Max.
- 2.4 Insulation resistance: 100 MΩ Min.
- 2.5 Total mating force: 3.57 Kgf Max.
- 2.6 Total unmating force: 1.0 Kgf Min.
- 2.7 Temperature range: -30°C~80°C
- 2.8 Waterproof: IPX7.

TOLERANCE UNSPECIFIED	
.x	±0.15
.xx	±0.10
.xxx	±0.05
Ang.	±1°

Singatron Enterprise Co., Ltd.			
TITLE	MICRO USB 5S B TYPE 防水型DIP型		
DWN	xiayouhong	PART NO. 2UB7241B01-730	
CHKD	2015.05.10	SCALE 1:1	UNIT: mm
APVD		SIZE: A3	SHEET:1 OF 1
REV: A			
CUSTOMER COPY			

1 2 3 4 5 6 7 8