

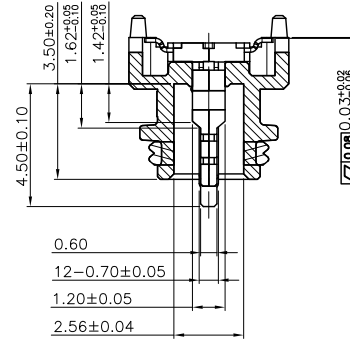

**RoHS Compliant HSF**  
2013/95/EC

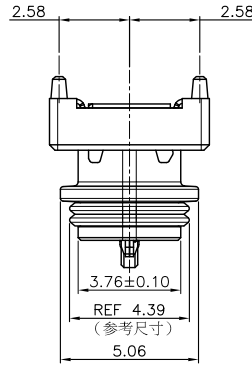

SECTION A-A

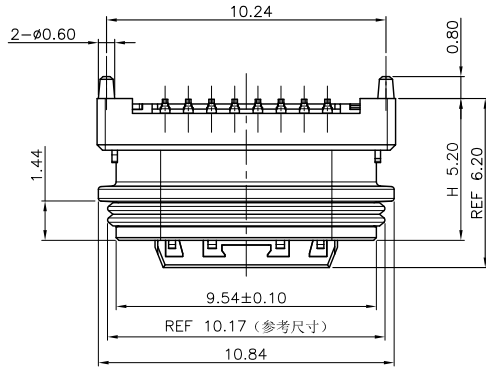
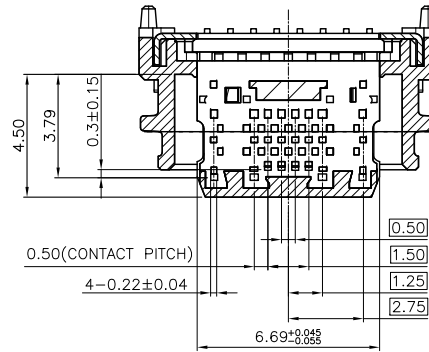
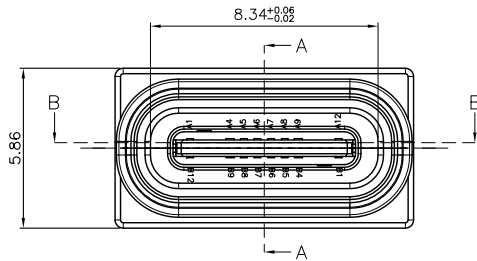

SECTION B-B

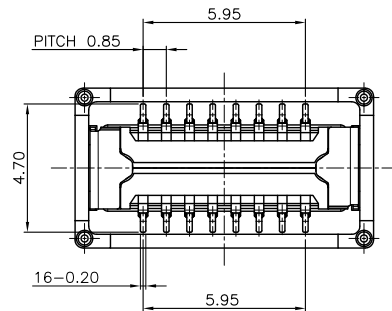

BOTTOM VIEW

Pin	Signal Name	Mating Sequence	Pin	Signal Name	Mating Sequence
A1	GND	First	B12	GND	First
A4	V <sub>BUS</sub>	First	B9	V <sub>BUS</sub>	First
A5	CC1	Second	B8	SBU2	Second
A6	Dp1	Second	B7	Dn2	Second
A7	Dn1	Second	B6	Dp2	Second
A8	SBU1	Second	B5	CC2	Second
A9	V <sub>BUS</sub>	First	B4	V <sub>BUS</sub>	First
A12	GND	First	B1	GND	First
SHELL	GND		SHELL	GND	

NOTE:

- MATERIAL:
  - INSULATOR: HIGH TEMPERATURE PLASTIC UL 94 V-0;
  - CONTACT: COPPER ALLOY(T=0.15mm)
  - SHELL:STAINLESS STEEL(T=0.25mm)
- ELECTRICAL CHARACTERISTICS:
  - CONTACT RESISTANCE: 40mΩ Max FOR INITIAL. 10mΩ CHANGE AFTER TEST. MEASURE AT 20mV, 100mA.
  - CONTACT CURRENT RATING: 5A FOR V<sub>BUS</sub> PIN; 1.25A FOR VCONN PIN.
  - DIELECTRIC WITHSTANDING VOLTAGE: 100V AC R.M.S.
  - INSULATION RESISTANCE 100MΩ Min
  - OPERATING TEMPERATURE: -40°C ~ 85°C
- MECHANICAL CHARACTERISTICS:
  - MATING FORCE: 5~20 N.
  - UNMATED FORCE: 6~20N AFTER TEST
  - DURABILITY: 10,000 CYCLES
- PLATING
  - TERMINAL CONTACT: (SEE TAB) GOLD PLATING ALL OVER 50u" Min NICKEL AND 80u"Min Tin ALL OVER 50u" Min NICKEL ON SOLDER AREA
  - OUT SHELL: 50u" Min. NICKEL ALL OVER

2UC16W-62X23-24A

- 1: Tray 2: Tape reel
- 1: G/F 2: 5u" 3: 10u"
- 4: 15u" 5: 30u"

TOLERANCES UNLESS OTHERWISE SPECIFIED

UNIT	(MM)
X.	±0.50
X.X	±0.30
X.XX	±0.20
X.XXX	±0.10
ANGEL	±2'

REV.	DESCRIPTION	ECN NO.	DWN.	CHK.	APVD.	DATE
B	取消点焊		YAN	YWL	FCC	2023.06.12
A	NEW DARWING	ECN NO.	YYT	YWL	FCC	2022.05.19

Singatron Enterprise Co., Ltd.

TITLE	USB CF VERTICAL WATERPROOF HS.20 SMT TYPE FOR 2.0 IPX8 WOL				
DWN	YYT	PART NO.	2UC16W-62X23-24A		
CHKD	2022.05.19	SCALE	1:1	UNIT:	mm
APVD	FCC	SIZE:	A3	SHEET:	1 OF 3
		REV:	B		

CUSTOMER COPY



**RoHS Compliant HSF**  
2013/95/EC

机壳面板

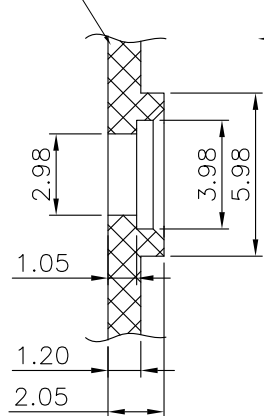

硅胶密封圈

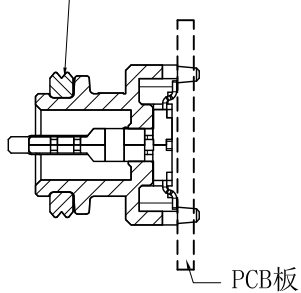

PCB板

组装方式，左右方向装配

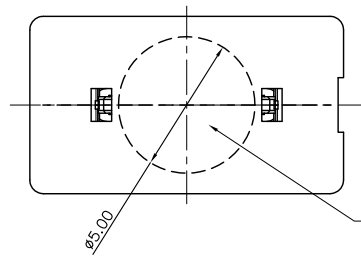

PICK PLACE AREA

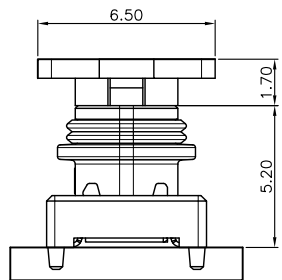
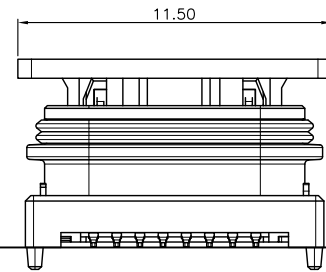

WITH CAP

机壳面板与密封圈  
建议压缩量50%Min

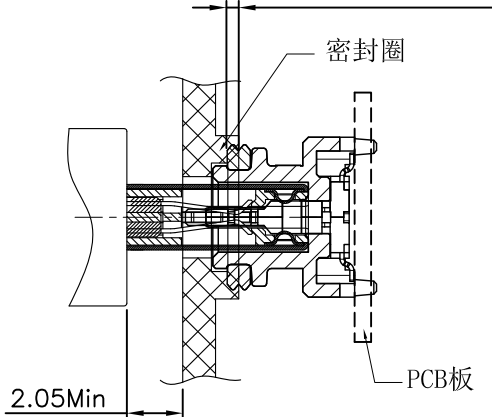

密封圈

PCB板

组装面板后公母头对插示意图

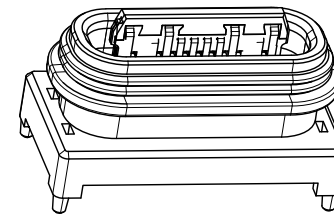
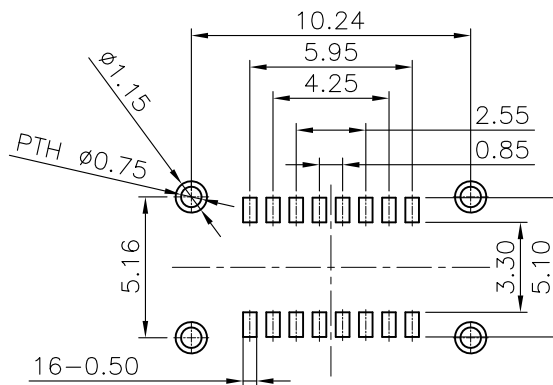

RECOMMEND P.C.B LAYOUT(COMPONENT SIDE)

TOLERANCE FOR PCB LAYOUT IS ±0.05

KEEP OUT AREA

REV.	DESCRIPTION	ECN NO.	DWN.	CHK.	APVD.	DATE
B	取消点焊		YAN	YWL	FCC	2023.06.12
A	NEW DARWING	ECN NO.	YYT	YWL	FCC	2022.05.19

TOLERANCES UNLESS OTHERWISE SPECIFIED	
UNIT	(MM)
X.	±0.50
X.X	±0.30
X.XX	±0.20
X.XXX	±0.10
ANGEL	±2°

Singatron Enterprise Co., Ltd.

TITLE	USB CF VERTICAL WATERPROOF HS.20 SMT TYPE FOR 2.0 IPX8 WOL			
DWN	YYT	PART NO.	2UC16W-62X23-24A	
CHKD	2022.05.19	SCALE	1:1	UNIT: mm
APVD	FCC	SIZE	A3	SHEET: 2 OF 3
		REV:	B	

CUSTOMER COPY

1 2 3 4 5 6 7 8

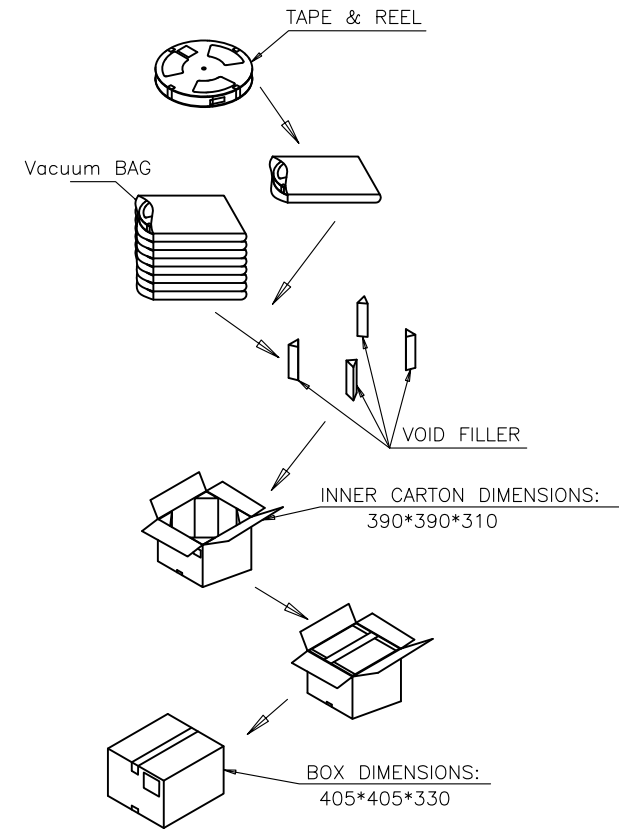
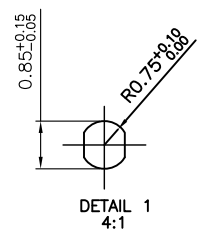
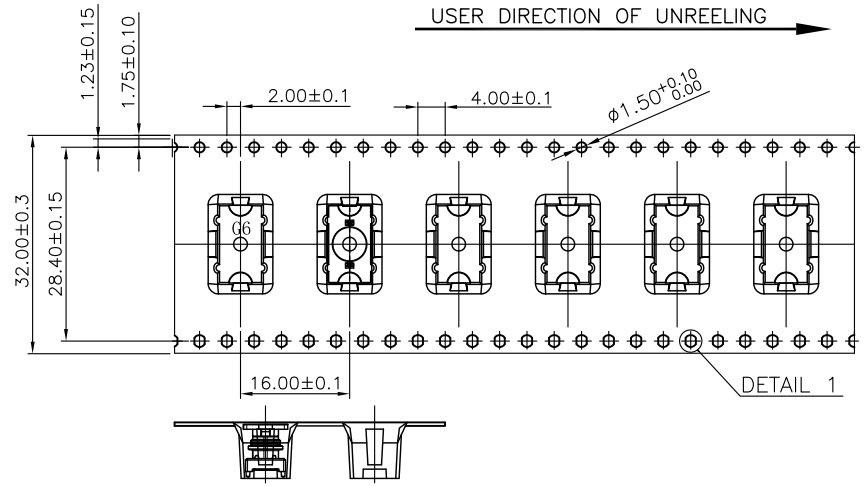
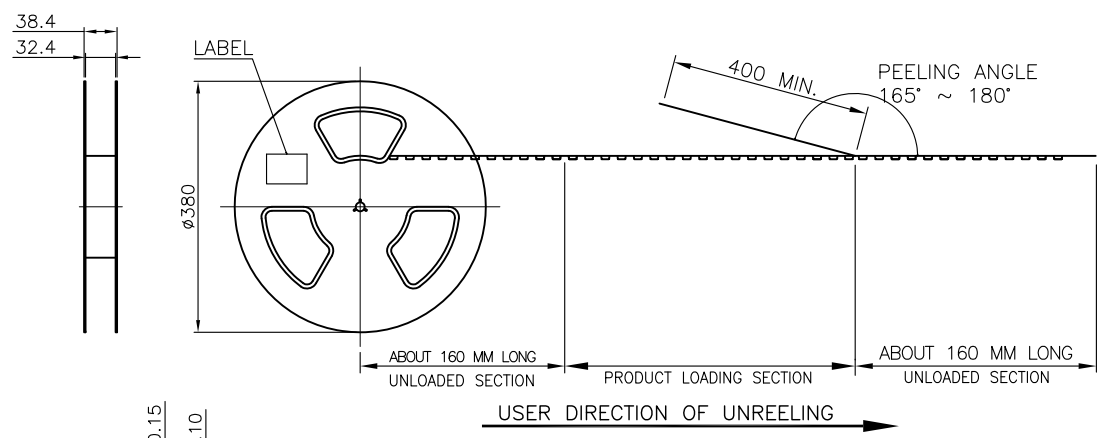

NOTE:

- MATERIAL:  
BOX: FIBREBOARD, CORRUGATED, DOUBLE WALL.  
TAPE: POLYSTYRENES, HEAT-RESISTANT TEMPERATURE: 120°C, BLACK COLOR.  
REEL: POLYSTYRENES, HEAT-RESISTANT TEMPERATURE: 70°C, BLUE COLOR.  
BAG: POLYETHYLENE, HEAT-RESISTANT TEMPERATURE: 100°C.
- PEELING STRENGTH: 0.1 ~ 1.3 N (10 ~ 130 GRAMS)
- PEELING SPEED: 300 mm/min.
- EACH BAG SHALL BE INCLUDED DESICCANT.

650	8	5200 PCS	-- KG	-- KG
PCS/ REEL	REELS/ CARTON	QUANTITY	GROSS WEIGHT	NET WEIGHT

B	取消点焊		YAN	YWL	FCC	2023.06.12
A	NEW DARWING	ECN NO.	YYT	YWL	FCC	2022.05.19
REV.	DESCRIPTION	ECN NO.	DWN.	CHK.	APVD.	DATE

TOLERANCES UNLESS OTHERWISE SPECIFIED

UNIT	(MM)
X.	±0.20
X.X	±0.15
X.XX	±0.10
X.XXX	±0.05
ANGEL	±1'

Singatron Enterprise Co., Ltd.

TITLE	USB CF VERTICAL WATERPROOF H5.20 SMT TYPE FOR 2.0 IPX8 WOL				
DWN	YYT	PART NO.	2UC16W-62X23-24A		
CHKD	2022.05.19	SCALE	1:1	UNIT:	mm
APVD	FCC	SIZE:	A3	SHEET:	3 OF 3
					REV: B
CUSTOMER COPY					

1 2 3 4 5 6 7 8