

Mated Condition(REF.)

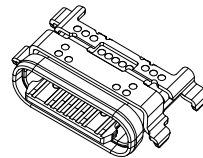

NOTES:

1. ELECTRICAL CHARACTERISTICS;
 - 1.1 CONTACT CURRENT RATING: 3A
 - 1.2 CONTACT RATED VOLTAGE: 5VDC;
 - 1.3 CONTACT RESISTANCE;
 - INITIAL: 40mohm Max. AFTER Δ < 10mohm
 - 1.4 INSULATION RESISTANCE: 100Mohm Min;
 - 1.5 WITHSTANDING STRENGTH: 100V AC FOR 1 MINUTE;
2. MECHANICAL CHARACTERISTICS;
 - 2.1 INSERTION FORCE: INITIAL 6-20N ; AFTER 5-20N;
 - 2.2 EXTRACTION FORCE: INITIAL 8-20N; AFTER 6-20N;
 - 2.3 DURABILITY: 10000 CYCLES
3. RoHS OR HF COMPLIANT
4. ENVIRONMENTAL PERFORMANCE:
 - OPERATING TEMPERATURE: -20°C ~ +85°C.
5. RECOMMENDED PROCESS:
 - THE PEAK TEMPERATURE ON THE BOARD SHALL MAINTAIN 10 ± 1 SECONDS AT 260 ± 5°C.

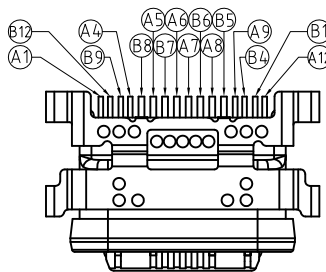
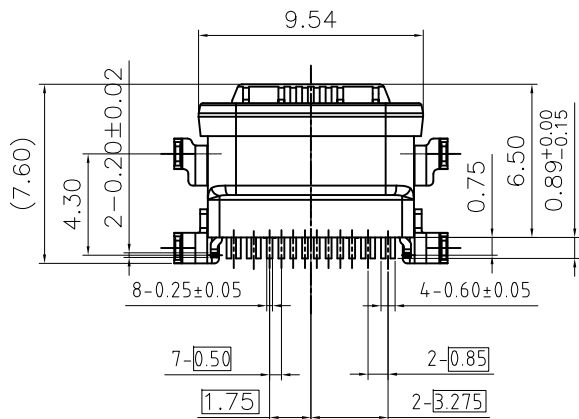
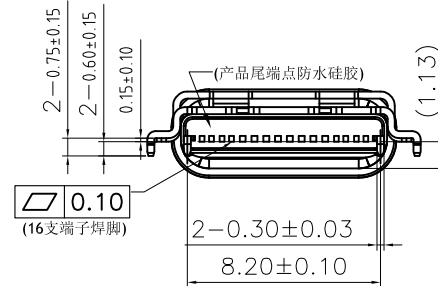
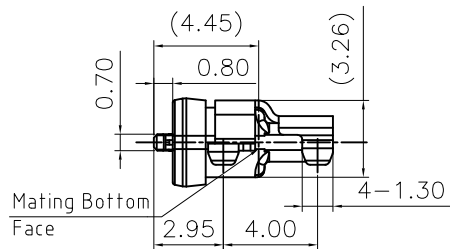
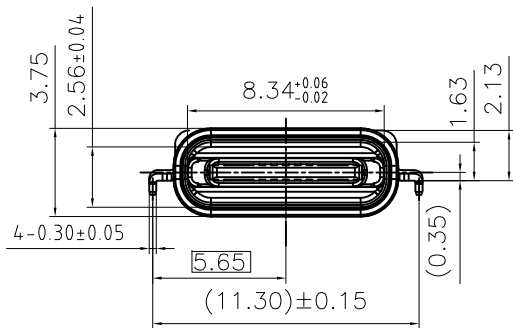

TABLE:

ITEM	NAME	Q'TY	MATERIAC	FINISH
H	LIM	1	SILICONE	UL94V-0, BLACK
G	GLUE	1	SILICONE(硅胶8896)	UL94V-0
F	OUTER SHELL	1	Stainless Steel, SUS304 T=0.30	OVER ALL: 50u" Min Ni UNDERPLATED SOLDER TAIL: G/F Au PLATED
E	INNER SHELL	1	Stainless Steel, SUS316L T=0.20	CLEAN
D	SOLDER-PLATE	1	Stainless Steel, SUS304 T=0.15	CLEAN
C	HOUSING	1	High-Temp Plastics PA10T	UL94V-0, Color: Black.
B	MID-PLATE	1	Stainless Steel, SUS301 T=0.20	OVER ALL: 50u" Min Ni PLATED
A	CONTACTS	16	Copper Alloy C18400 T=0.25mm	CONTACT AREA: 3u" Au Min SOLDER TAIL: Au 1.5u" Min OVER ALL: 50u" Ni UNDERPLATED
ITEM	NAME	Q'TY	MATERIAC	FINISH

DIMENSIONS TOLERANCE METRIC

- X : ±0.5
- X.X : ±0.38
- X.XX : ±0.25
- ANGLES
- X : ±1°
- X.X : ±0.5°

Singatron Enterprise Co., Ltd.

TITLE	USB Type-C母16pin防水型IPX8沉板1.13, 外露0.8		
DWN	PART NO. 2UC16W-CF190-SC		
CHKD	2022/11/11	SCALE 1:1	UNIT: mm
APVD	SIZE: A3	SHEET: 1 OF 2	REV: 01

CUSTOMER COPY



建议密封方式 Recommended sealing method

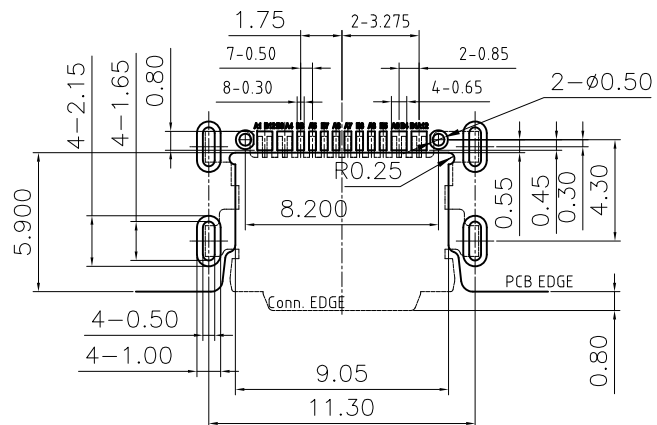
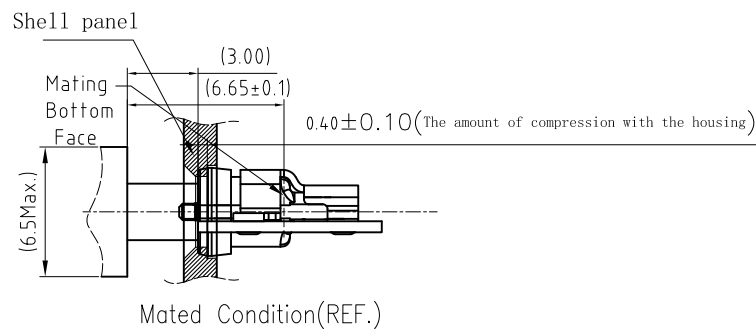
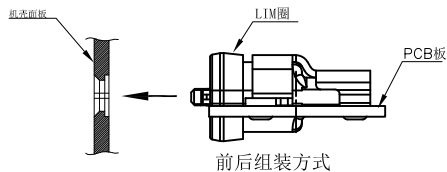

RECOMMENDED PCB LAYOUT
TOLERANCE:±0.05
STENCIL THICKNESS:0.12mm

Pin Assignments

Contact Number	Signal Name	Contact Number	Signal Name
A1	GND	B12	GND
/	/	/	/
A4	VBUS	B9	VBUS
A5	CC1	B8	SBU2
A6	Dp1	B7	Dn2
A7	Dn1	B6	Dp2
A8	SBU1	B5	CC2
A9	VBUS	B4	VBUS
/	/	/	/
A12	GND	B1	GND

DIMENSIONS TOLERANCE METRIC

X :±0.5
X.X :±0.38
X.XX :±0.25
ANGLES
X :±1°
X.X :±0.5°

Singatron Enterprise Co., Ltd.

TITLE	USB Type-C母16pin防水型IPX8沉板1.13,外露0.8		
DWN	PART NO. 2UC16W-CF190-SC		
CHKD	2022/11/11	SCALE 1:1	UNIT: mm
APVD	SIZE: A3	SHEET: 2 OF 2	REV: 01

CUSTOMER COPY