

NOTES:

1.ELECTRICAL CHARACTERISTICS:

1-1.CONTACT CURRENT RATING:  
5.0A FOR VBUS PIN AND ITS CORRESPONDING GND PIN.

1-2.CONTACT RESISTANCE:  
30 MILLIOHMS MAX FOR VBUS AND GND CONTACTS.  
40 MILLIOHMS MAX FOR ALL OTHER CONTACTS.

1-3.DIELECTRIC WITHSTANDING VOLTAGE:100 VRMS AC MIN.

1-4. INSULATION RESISTANCE:100 MEGOHMS MIN.

2.MECHANICAL CHARACTERISTICS:

2-1.CONNCTOR INSERTION FORCE:5~20N.  
AT A MAXIMUN RATE OF 12.5MM PER MINUTE.

2-2.CONNCTOR EXTRACTION FORCE:  
8~20N AT A MAXIMUN RATE OF 12.5MM PER MINUTE.  
6~20N AFTER DURABILITY TEST.

2-3.DURABILITY:10000 CYCLES.

2-4.OPERATING TEMPERATURE: -55°C TO +85°C

3.SALT SPRAY:48HOURS.

4.DIMENSIONS ARE IN MILLIMETERS, BRACKETED DIMENSIONS ARE INCHES EQUIVALENTS.

5.RECOMMENED PROCESS: IR REFLOW 260°C.3~5SECONDS.

6.THE CONNCTOR IS ROHS COMPLIANT AND HALOGEN FREE COMPLIAN.

8. Mark "⊗" REFERS TO FAI INSPECTION DIMENSION

P/N.: 2UC24W-1712-XX0H

CONTACT AREA PLATING

03: Au 3u"  
15: Au 15u"  
30: Au 30u"

Pin	Signal Name	Pin	Signal Name
A1	GND	B12	GND
A2	SSTXp1	B11	SSRXp1
A3	SSTXn1	B10	SSRXn1
A4	VBUS	B9	VBUS
A5	CC1	B8	SBU2
A6	Dp1	B7	Dn2
A7	Dn1	B6	Dp2
A8	SBU1	B5	CC2
A9	VBUS	B4	VBUS
A10	SSRXn2	B3	SSTXn2
A11	SSRXp2	B2	SSTXp2
A12	GND	B1	GND

TABLE:

ITEM	PART NAME	QTY	Material&Plating
1	SUB-SHELL	1	SUS304 t=0.15, Ni PLATED 30u"
2	MAIN-SHELL	1	SUS316L t=0.20 CLEANING
3	LATCH	1	SUS301 t=0.15, Ni PLATED 30u"
4	HOUSING	1	PA9T+30%G.F, HF BLACK
5	CONTACT	24	C7025 t=0.12,Ni UNDER PLATED OVER. Au PLATED ON THE CONTACT AREA, GOLD FLASH PLATED ON THE SOLDER TAILS.
6	LIM	1	CHN-LIMS-60A/B; Pull force 300g



UNLESS OTHERWISE SPECIFIED TOLERANCES				Singatron Enterprise Co., Ltd.			
DECIMALS:		ANGLES:		TITLE	USB TYPE C 24PIN 防水型		
DIM	TOL	DIM	TOL	DWN	Tony	PART NO. 2UC24W-1712-XX0H	
X.	±0.50	X.	±2°	CHKD	2021.10.7	SCALE 1:1	UNIT: mm
X.X	±0.30	X.X	±1°	APVD	Andy	SIZE: A3	SHEET: 1 OF 2
X.XX	±0.20	X.XX	±1'	REV: A1			
X.XXX	±0.10	X.XXX	///	CUSTOMER COPY			

1 2 3 4 5 6 7 8

F

E

D

C

B

A

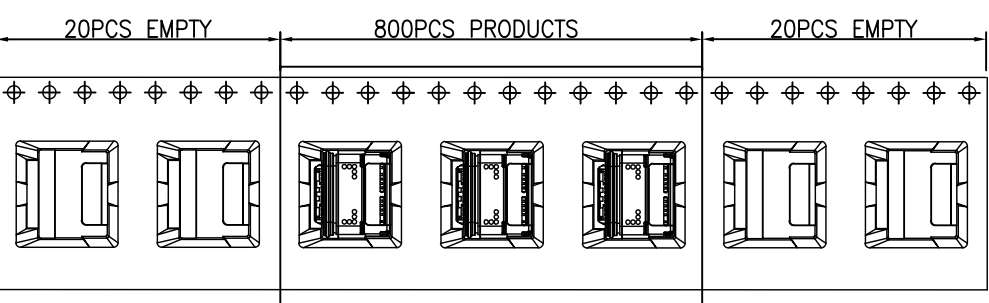

REEL OFF DIRECTION  
←

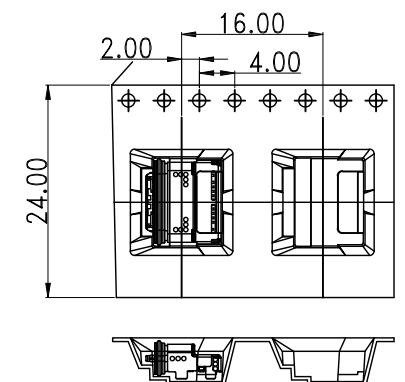

CUSTOMER UNWINDING DIRECTION  
→

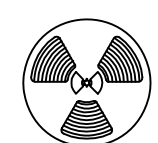
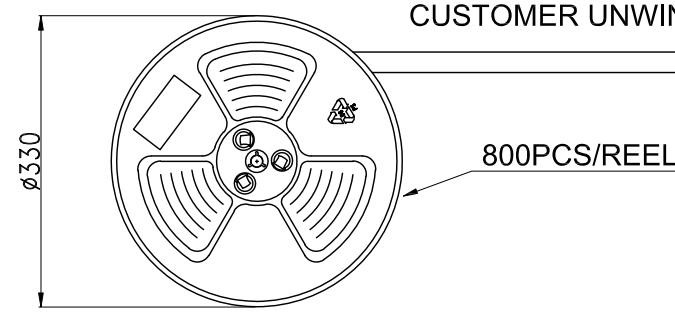

800PCS/卷

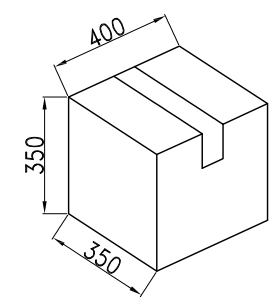

8000PCS/10卷/箱

UNLESS OTHERWISE SPECIFIED TOLERANCES				Singatron Enterprise Co., Ltd.			
DECIMALS:		ANGLES:		TITLE	USB TYPE C 24PIN 防水型		
DIM	TOL	DIM	TOL	DWN	Tony	PART NO.	2UC24W-1712-XX0H
X.	±0.50	X.	±2°	CHKD	2021.10.7	SCALE 1:1	UNIT: mm
X.X	±0.30	X.X	±1°	APVD	Andy	SIZE: A3	SHEET: 2 OF 2
X.XX	±0.20	X.XX		REV: A1			
X.XXX	±0.10	X.XXX		CUSTOMER COPY			

1 2 3 4 5 6 7 8