

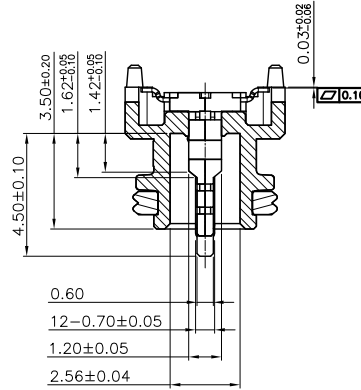

RoHS Compliant HSF
2013/95/EC

Pin	Signal Name	Mating Sequence	Pin	Signal Name	Mating Sequence
A1	GND	First	B12	GND	First
A2	SSTXp1	Second	B11	SSRXp1	Second
A3	SSTXn1	Second	B10	SSRXn1	Second
A4	VBUS	First	B9	V _{BUS}	First
A5	CC1	Second	B8	SBU2	Second
A6	Dp1	Second	B7	Dn2	Second
A7	Dn1	Second	B6	Dp2	Second
A8	SBU1	Second	B5	CC2	Second
A9	VBUS	First	B4	V _{BUS}	First
A10	SSRXn2	Second	B3	SSTXn2	Second
A11	SSRXp2	Second	B2	SSTXp2	Second
A12	GND	First	B1	GND	First
SHELL	GND		SHELL	GND	

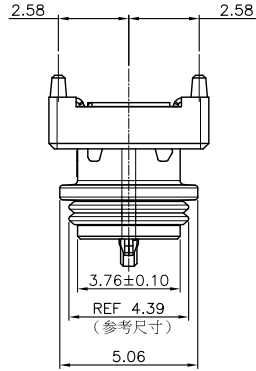
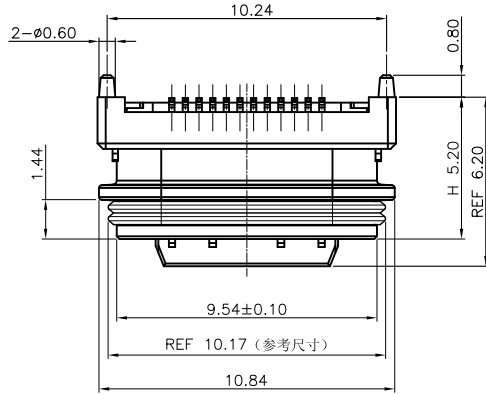

SECTION A-A

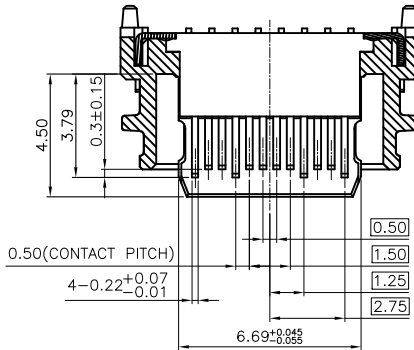
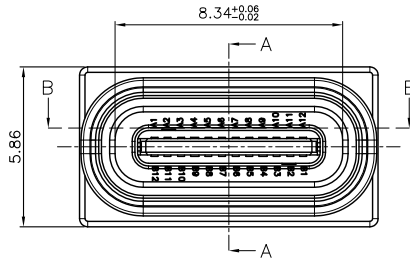

SECTION B-B

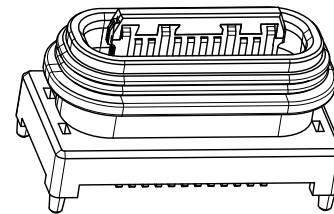

3D VIEW

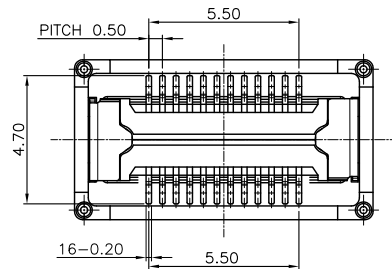

BOTTOM VIEW

NOTE:

1. MATERIAL:

1.1 INSULATOR: HIGH TEMPERATURE PLASTIC UL 94 V-0;BLACK.

1.2 CONTACT: COPPER ALLOY(T=0.15mm)

1.3 SHELL:STAINLESS STEEL(T=0.25mm)

2.ELECTRICAL CHARACTERISTICS:

2.1 CONTACT RESISTANCE: 40mΩ Max FOR INITIAL. 10mΩ CHANGE AFTER TEST. MEASURE AT 20mV, 100mA.
2.2 CONTACT CURRENT RATING: 5A FOR VBUS PIN; 1.25A FOR VCONN PIN.

2.3 DIELECTRIC WITHSTANDING VOLTAGE: 100V AC R.M.S.

2.4 INSULATION RESISTANCE 100MΩ Min

2.5 OPERATING TEMPERATURE: -40°C ~ 85°C

3 MECHANICAL CHARACTERISTICS:

3.1 INSERTION FORCE: 5~20 N.

3.2 EXTRACTION FORCE: 6~20N AFTER TEST

3.3 DURABILITY: 10,000 CYCLES

3.4 THE EXTRACTION FORCE SHALL BE WITHIN THE RANGE OF 6N~20N AFTER 10000.

4.PLATING

4.1 TERMINAL CONTACT: (SEE TAB) GOLD PLATING ALL OVER 50u" Min NICKEL AND 80u"Min Tin ALL OVER 50u" Min NICKEL ON SOLDER AREA

4.2 OUT SHELL: 50u" Min. NICKEL ALL OVER

5.PART NUMBER:

2UC24W-62X26-23A

- 1: Tray 2: Tape reel
- 1: G/F 2: 5u" 3: 10u"
- 4: 15u" 5: 30u"

REV.	DESCRIPTION	ECN NO.	DWN.	CHK.	APVD.	DATE
B	取消点焊		YAN	YWL	FCC	2023.06.12
A	NEW DARWING	ECN NO.	YYT	YWL	FCC	2022.05.19

TOLERANCES UNLESS OTHERWISE SPECIFIED	
UNIT	(MM)
X.	±0.50
X.X	±0.30
X.XX	±0.20
X.XXX	±0.10
ANGEL	±2'

Singatron Enterprise Co., Ltd.

TITLE	USB 4.0 CF VERTICAL WATERPROOF H5.20 SMT TYPE IPX8 WOL				
DWN	YYT	PART NO.	2UC24W-62X26-23A		
CHKD	2022.05.19	SCALE 1:1	UNIT:	mm	
APVD	FCC	SIZE: A3	SHEET:1 OF 3	REV: B	

CUSTOMER COPY



RoHS Compliant HSF
2013/95/EC

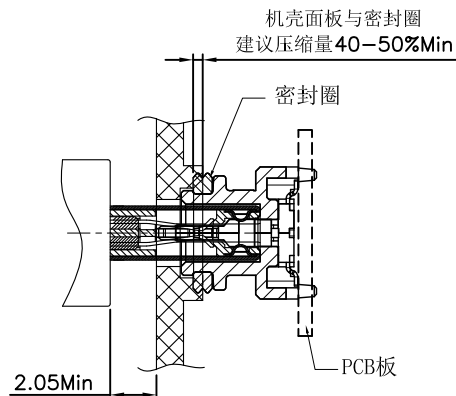

组装面板后公母头对插示意图

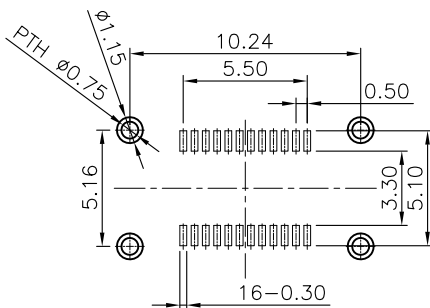

RECOMMEND P.C.B LAYOUT (COMPONENT SIDE)
TOLERANCE FOR PCB LAYOUT IS ± 0.05
KEEP OUT AREA

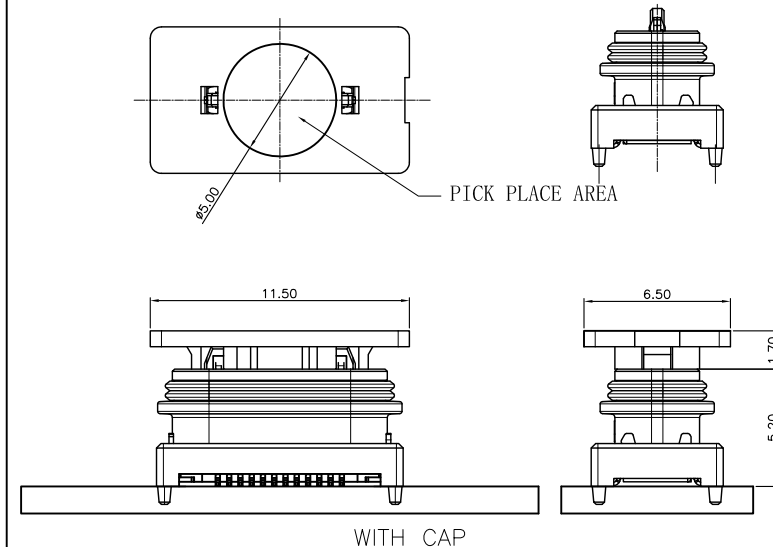

WITH CAP

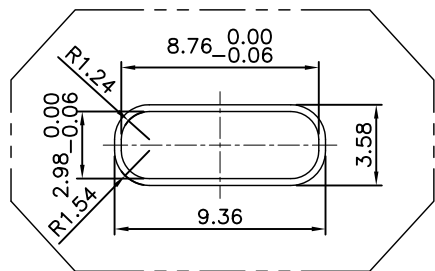

机壳面板

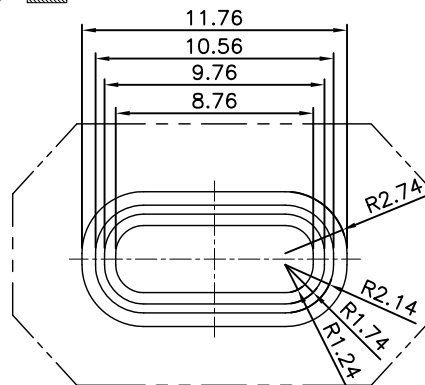
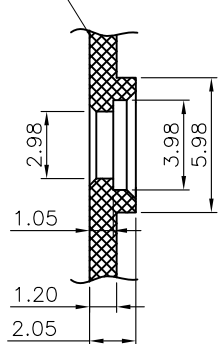

硅胶密封圈

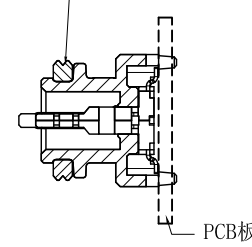

组装方式，左右方向装配

REV.	DESCRIPTION	ECN NO.	DWN.	CHK.	APVD.	DATE
B	取消点焊		YAN	YWL	FCC	2023.06.12
A	NEW DARWING	ECN NO.	YYT	YWL	FCC	2022.05.19

TOLERANCES UNLESS OTHERWISE SPECIFIED	
UNIT	(MM)
X.	± 0.50
X.X	± 0.30
X.XX	± 0.20
X.XXX	± 0.10
ANGEL	$\pm 2'$

Singatron Enterprise Co., Ltd.

TITLE	USB 4.0 CF VERTICAL WATERPROOF H5.20 SMT TYPE IPX8 WOL			
DWN	YYT	PART NO.	2UC24W-62X26-23A	
CHKD	2022.05.19	SCALE	1:1	UNIT: mm
APVD	FCC	SIZE: A3	SHEET: 2 OF 3	REV: B

CUSTOMER COPY

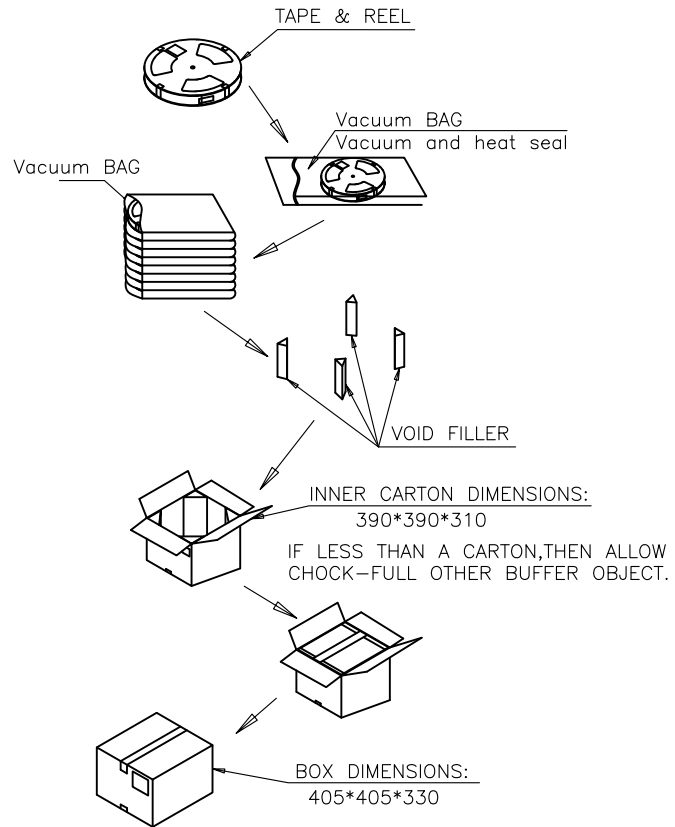
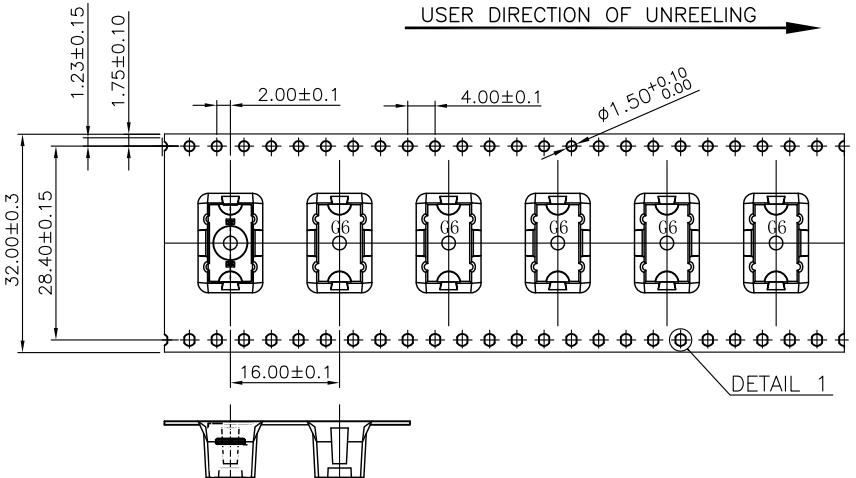
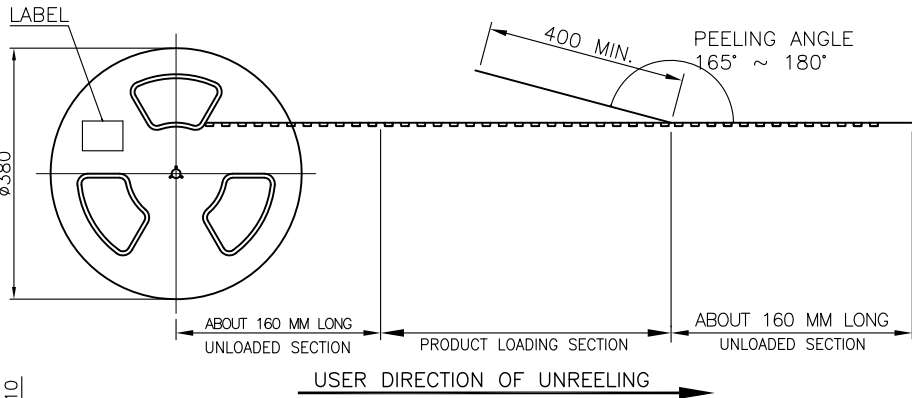
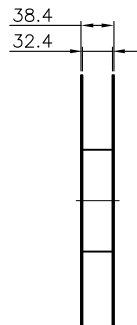

NOTE:

- MATERIAL:
BOX: FIBREBOARD, CORRUGATED, DOUBLE WALL.
TAPE: POLYSTYRENES, HEAT-RESISTANT TEMPERATURE: 120°C, LUCENCY COLOR.
REEL: POLYSTYRENES, HEAT-RESISTANT TEMPERATURE: 70°C, BLUE COLOR.
BAG: POLYETHYLENE, HEAT-RESISTANT TEMPERATURE: 100°C.
- PEELING STRENGTH: 0.1 ~ 1.3 N (10 ~ 130 GRAMS)
- PEELING SPEED: 300 mm/min.
- EACH BAG SHALL BE INCLUDED DESICCANT.
- STORAGE CONDITIONS: TEMPERATURE: 18°C ~ 25°C, HUMIDITY: <60%, AFTER REMOVAL VACUUM PACKAGING WITHIN A WEEK OF WELDING PLATE USE.

B	取消点焊		YAN	YWL	FCC	2023.06.12
A	NEW DARWING	ECN NO.	YYT	YWL	FCC	2022.05.19
REV.	DESCRIPTION	ECN NO.	DWN.	CHK.	APVD.	DATE

TOLERANCES UNLESS OTHERWISE SPECIFIED	
UNIT	(MM)
X.	±0.20
X.X	±0.15
X.XX	±0.10
X.XXX	±0.05
ANGEL	±1°

650	8	5200 PCS	-- KG	-- KG
PCS/ REEL	REELS/ CARTON	QUANTITY	GROSS WEIGHT	NET WEIGHT

Singatron Enterprise Co., Ltd.				
TITLE	USB 4.0 CF VERTICAL WATERPROOF H5.20 SMT TYPE IPX8 WOL			
DWN	YYT	PART NO. 2UC24W-62X26-23A		
CHKD	2022.05.19	SCALE 1:1	UNIT: mm	
APVD	FCC	SIZE: A3	SHEET: 3 OF 3	REV: B
<i>CUSTOMER COPY</i>				