

REV	ZONE	REVISION	DATE

Green Product

Specification:
 Contact Resistance: 30m Ohm Max.
 Insulation Resistance: 1000M Ohm Min. At 500VDC.
 Rated Voltage And Current: 1.5A At 250VAC Minimum.
 Dielectric Withstanding Voltage:
 500V AC (rms) for 1 Minute(Rev. 2.0)
 Durability (Life Test): 1500 Cycles
 Insertion Force: 35 Newton Maximum.
 Extraction Force: 10 Newton Minimum.

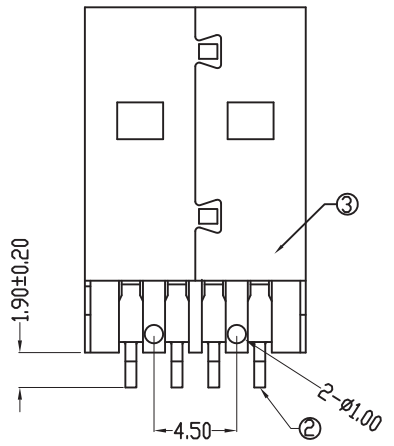
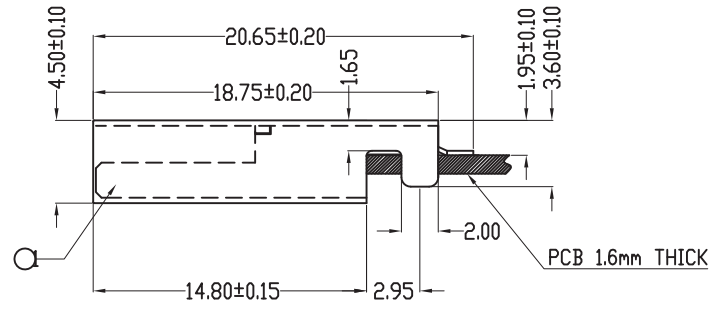
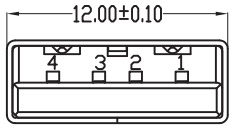
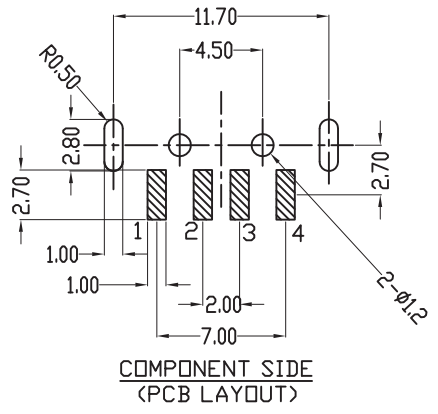
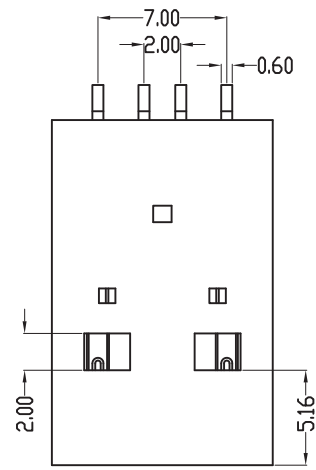

PACKING STYLE: TAPE REEL

NO.	NAME	MATERIAL	FINISH	REMARK	Q'TY
1	HOUSING	NYLON PA9T G.F.	BLACK		1
2	PIN TERM.	BRASS EH T:0.25 mm	GOLD/TIN PLATED	Gold:30u" ; NI:40~60u" ; TIN:120u" (100% pure Tin of lead free plating)	4
3	SHELL	SPCC T:0.3 mm	NICKEL PLATED	NI:80~120u"	1

SINGATRON U.S.A.

COMPUTER NO.		UNIT	SCALE	PART NAME	
APPD.	CKD.	mm	1:1	USB. TYPE A PLUG FLAT90° SMT	
DWG.	DATE	TOLERANCE	PART NO.	REV.	
JASON	10-02-14	X. ±0.38 .X ±0.25 .XX ±0.13 .XXX ±0.05	2UP-001MSK7A1NB2TRL	A0	