

REV.	ECN NO OR DESCRIPTION	REVISED	DATE
A	PDR RELEASE	IVY-C	2010.01.18

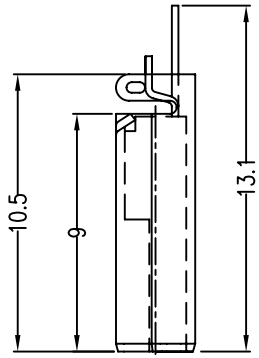

**SPECIFICATIONS:**

1. MATING FORCE: 35N MAX.
2. WITHDRAWAL FORCE: 7N MIN.
3. CURRENT RATING: 1.0 Amp
4. CONTACT RESISTANCE: 30m OHMS MIN.
5. INSULATION RESISTANCE: 100M OHMS MIN.
6. DIELECTRIC WITHSTANDING VOLTAGE: 500VAC FOR 1 MINUTE.
7. TO CONFORM TO SINGATRON HAZARDOUS SUBSTANCE FREE SPEC.
8. GREEN PRODUCT IDENTIFICATION LABEL ON PACKAGING: **G.P. PASS**
9. PACKAGE: SEE "2UP1521 SERIES" PACKAGE.
9. OTHER GENERAL SPEC. TO REFER "2UP1521 SERIES SPEC".

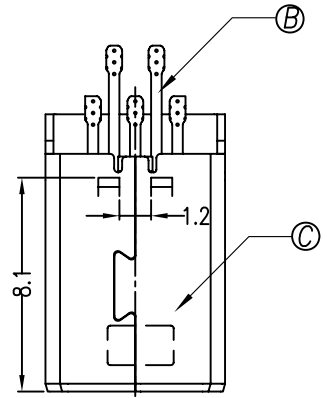
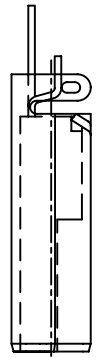
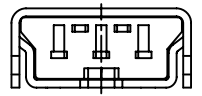
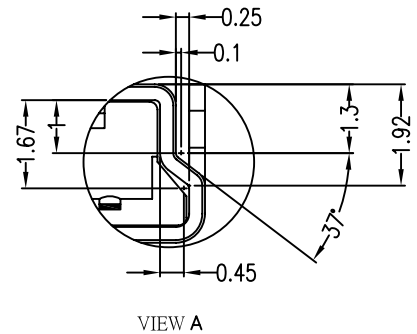
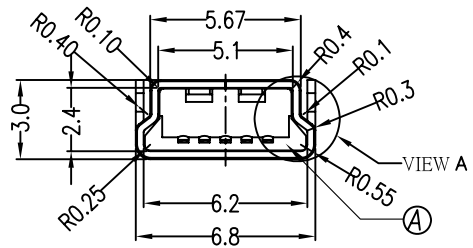

**PART NO.**

**2UP1521-000111**

- PACKAGE
- 1: PLASTIC BAG
- HOUSING COLOR
- 1: BLACK
- CONTACT PLATING
- 1: GOLD FLASH ON MATING AREA
- TIN PLATED ON SOLDER AREA

C	SHELL	1	SPCC	NICKEL PLATED
B	CONTACT	5	BRASS	SEE PART NO.
A	HOUSING	1	PBT, UL 94V-0	BLACK
NO	DESCRIPTION	QTY	MATERIAL	PLATING & COLOR
UNLESS OTHERWISE SPECIFIED TOLERANCES		Singatron Enterprise Co., Ltd. 信音企業股份有限公司		
DECIMALS: ANGLES:		TITLE: MINI USB MALE B TYPE, 5P SLIM		
X	:±0.5	X	:±2°	DWN MY-C 2010.01.18 PART NO. 2UP1521-000111
X.X	:±0.3	X.X	:±1°	CHKD DWD-T 2010.01.18 SCALE 1:1 UNIT: mm
X.XX	:±0.2	APVD	DWD-T 2010.01.18	SIZE: A3 SHEET: 1 OF 1 REV: A
<b>CUSTOMER COPY</b>				