

REV.	ECN NO OR DESCRIPTION	REVISED	DATE
A	PDR NO. T170607-2A	EVEN	2017.06.20

**SPECIFICATIONS:**

**1. ELECTRICAL CHARACTERISTICS:**

1-1. Rating Current: PIN1&PIN4 (Vbus&Corresponding ground PIN) 1.8A MAX  
Other PINS 0.25A min.

1-2. Rating Voltage: 30V AC

1-3. Contact Resistance: PIN1&PIN4: 30 mΩ MAX. Other PINS: 50 mΩ

1-4. INSULATION RESISTANCE: 100MΩ MIN.

1-5. Withstanding Voltage: AC 100V between adjacent contacts

**2. MECHANICAL CHARACTERISTICS:**

2-1. INSERTION FORCE: 3.57Kg MAX.

2-2. WITHDRAWAL FORCE: 1.0Kg MIN.

3. LIFE TEST: 1500 CYCLES.

4. Temperature Range: -30°C+80°C

5. TO CONFORM TO THE SINGATRON HAZARDOUS SUBSTANCE FREE SPEC.

6. HALOGEN FREE PRODUCT IDENTIFICATION LABEL ON PACKAGING.

7. PACKAGE: SEE "2UP1530-000111F" PACKAGE.

8. FOR REFLOW SOLDERING LEAD-FREE PROCESS.

9. OTHER GENERAL SPEC. TO REFER "2UP1530-000111F SPEC".



**PART NO.**

**2UP1530-000111F**

SUFFIX: HALOGEN FREE

PACKAGE

1: TAPE & REEL

HOUSING COLOR

1: BLUE

CONTACT PLATING

1: GOLD FLASH(0.6u" MIN.) ON CONTACT AREA,

30u" MIN. Bright Sn PLATING ON SOLDER AREA,

30u" MIN. Ni UNDERPLATING OVERALL.

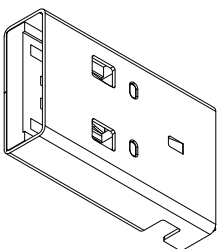
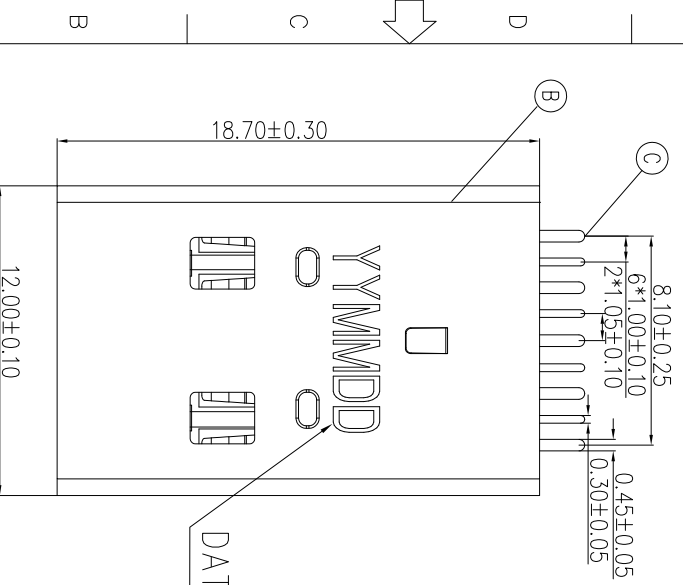
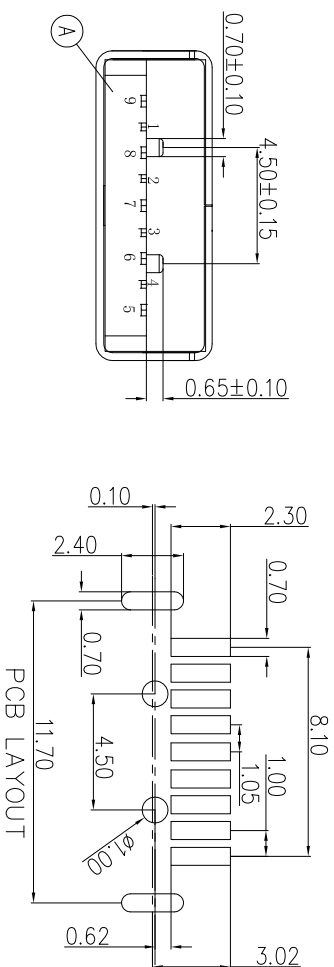

C	CONTACT	9	C2680	SEE PART NO.
B	SHELL	1	SPCC	30u" Min. Ni PLATED
A	HOUSING	1	LCP UL 94V-0	BLUE
NO	DESCRIPTION	QTY	MATERIAL	PLATING & COLOR

UNLESS OTHERWISE SPECIFIED TOLERANCES

DECIMALS: ANGLES:

X :±0.5 X :±2°

X.X :±0.3 X.X :±1°

X.XX :±0.2

TITLE: USB3.0 A TYPE, 9P PLUG

DWN: [EHSI 2020.12.29] PART NO. 2UP1530-000111F

CHKD: SCALE 1:1 UNIT: mm

APVD: [MRL 2020.12.29] SIZE: A3 SHEET: 1 OF 1 REV: A

CUSTOMER COPY