

REV.	ECN NO OR DESCRIPTION	REVISED	DATE
A	PRODUCT RELEASE	JASMINE	3/7-'06

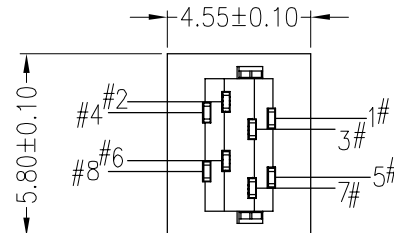
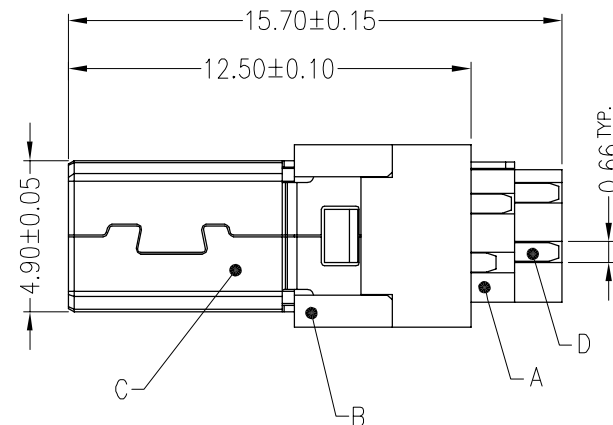
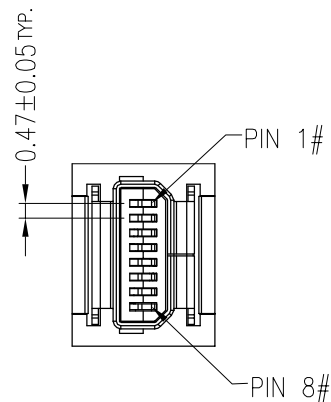

Specifications:

1.Electrical:

- 1-1 Rating: AC 5V/0.5A
- 1-2 Contact resistance: 50m Ohm or less
- 1-3 Insulation Resistance: 100M Ohm Min at DC500V
- 1-4 Dielectric Withstanding Voltage: AC 100V for 1minute

2.Mechanical:

- 2-1 Insertion Force: 35N(3.57kgf)Max.
- 2-2 Withdrawal Force: 1N(0.1kgf)Min.
- 3.Solder heat resistance: Wave soldering 260°C 10 Secs.

4.To conform to the "SE-01-001" & "ROHS DIRECTIVE"

5.Green product identification label in packing: **G.P. PASS**

6.For wave soldering LEAD-FREE process.

7.Information: 2UP2000-100112

- PACKAGE
- 2: PE BAG
- BODY COLOR
- 1: BLACK
- CONTACT PLATING
- 1: GOLD PLATING
- PRODUCT TYPE
- 1: PLUG

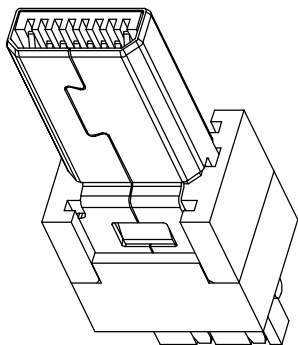
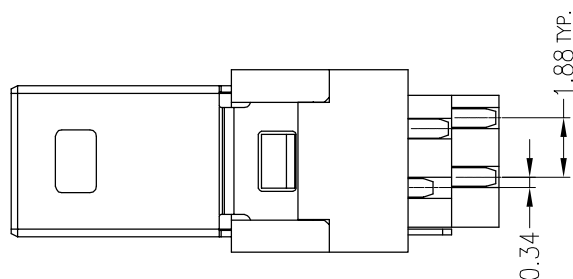
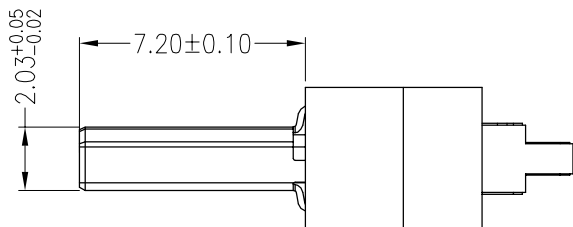

C	SHELL	1	BRASS	GOLD 1μ"
B	TERMINAL	8	PHOSPHOR	GOLD 3μ"
A	HOUSING	1	HIGH TEMPERATURE THERMOPLASTIC.	BLACK COLOR
NO	DESCRIPTION	QTY	MATERIAL	PLATING & COLOR

UNLESS OTHERWISE SPECIFIED TOLERANCES

Singatron Enterprise Co., Ltd.
信音電子(中山)有限公司

DECIMALS:	ANGLES:	TITLE	MINI USB CONNECTOR <DIP TYPE>		
X :±0.5	X :±2°	DWN	JASMINE 06.3.7	PART NO.2UP2000-100112	
X.X :±0.3	X.X :±1°	CHKD	SCALE:	UNIT: mm	
X.XX :±0.2		APVD	SEAN 06.3.7	SIZE: A3	SHEET: OF REV: A
CUSTOMER COPY					