

REV.	ECN NO OR DESCRIPTION	REVISED	DATE
A	FIRST EDITION RELEASED	HAIHUA	7/9'07
B	為改善插拔力備小變更PLUG頭部尺寸 ECN NO:C070166-2/2	HAIHUA	09/11'07
C	NOTE增加拔出力初始值的描述 ECN NO:C080015-2/2	CHARLIE	01/25'08

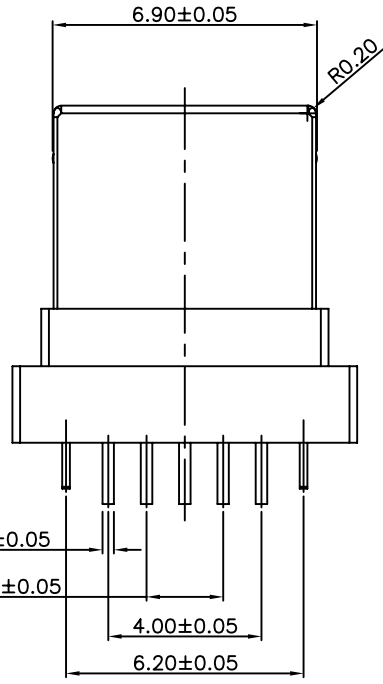
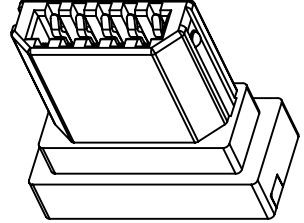
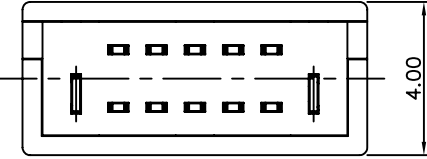
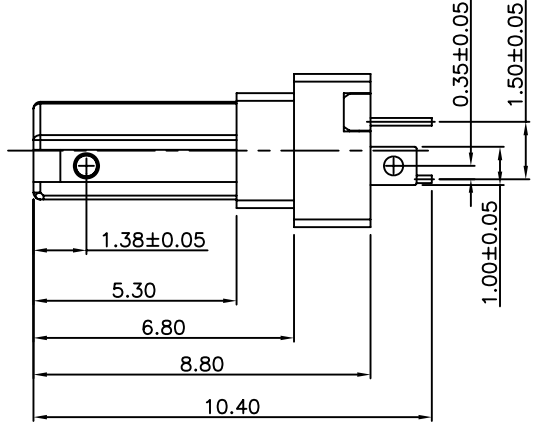
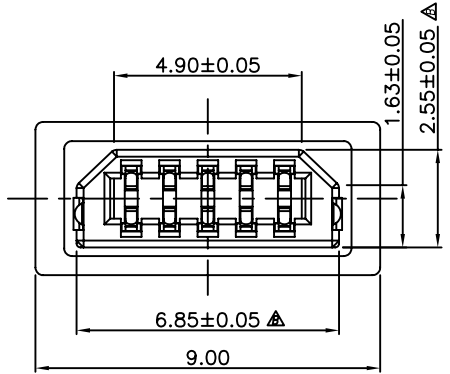

- NOTE:
- MATING FORCE 2Kg Max.  
 ▲UNMATING FORCE : INITIAL 0.8Kg Min.  
 FINAL 0.2Kg Min.
  - WORKING VOLTAGE : 30V MAX.
  - TO CONFORM TO THE SINGATRON HSF SPECIFICATION.
  - GREEN PRODUCT IDENTIFICATION LABEL IN PACKING: **G.P. PASS**

NO	DESCRIPTION	QTY	MATERIAL	PLATING&COLOR
3	LATCH	2	COPPER ALLOY 0.2t	NI100u"
2	CONTACT	10	COPPER ALLOY 0.2t	NI50u"/Au1u"
1	BODY	1	PA9T	BLACK

UNLESS OTHERWISE SPECIFIED TOLERANCES		Sngatron Electronic(Chung-Shan) Co., Ltd. 信音電子(中山)有限公司	
DECIMALS:	ANGLES:	TITEL 10PIN MMI PLUG	
X :±0.5	X :±2°	DWN CHARLIE 01/25'08	PART NO. 2UP2001-10P112
X.X :±0.3	X.X :±1°	CHKD MUYUAN 01/25'08	SCALE: N/A UNIT: mm
X.XX :±0.2		APVD SEAN 01/25'08	SIZE: A4 SHEET: 10F1 REV: C
<b>CUSTOMER COPY</b>			