

REV.	ECN NO.	OR DESCRIPTION	REVISED	DATE
A		PRODUCT RELEASE	Longjiang	2016/10/28
B	ECN NO: C170057	MODIFY DRAWING	Longjiang	2017/08/03
C	ECN NO: C202007-001	MODIFY DRAWING	Ye Wei	2020/09/15

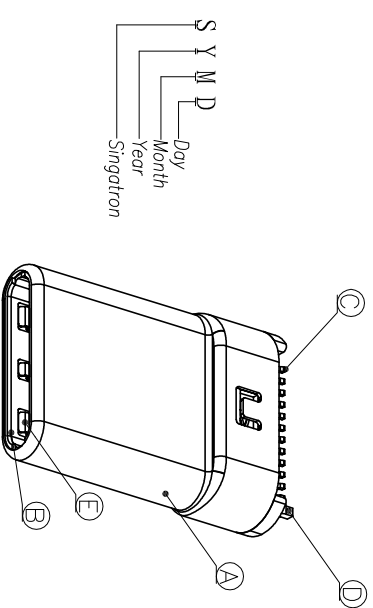

SYMD
Day
Month
Year
Singatron

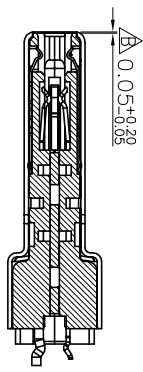
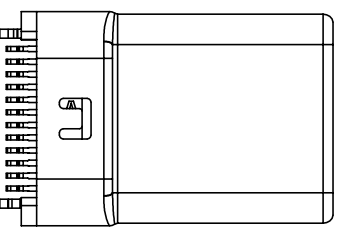
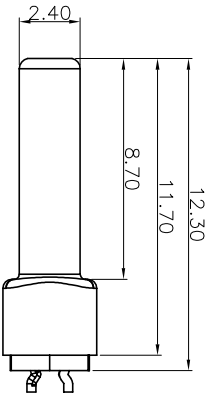
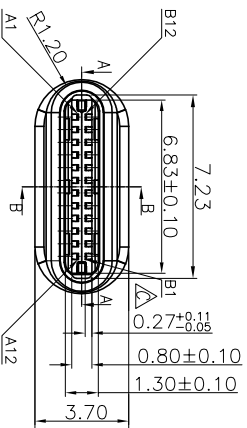
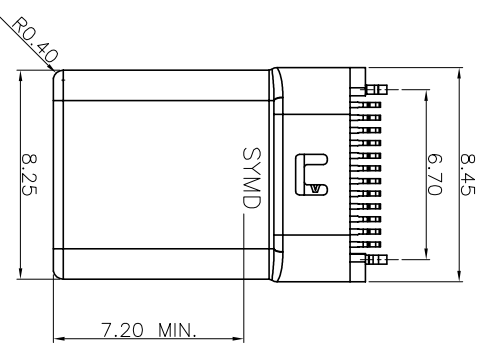

- SPECIFICATIONS:
- ELECTRICAL CHARACTERISTICS:
 - RATING: 5A.
 - CONTACT RESISTANCE: 40mΩ MAX.
 - INSULATION RESISTANCE: 100 MEGOHMS MIN. BY 100V DC.
 - DIELECTRIC WITHSTANDING VOLTAGE: 100V AC FOR 1 MINUTE.
 - MECHANICAL CHARACTERISTICS:
 - INSERTION FORCE : 0.5~2.0kgf.
 - WITHDRAWAL FORCE : 0.8~2.0kgf.

3. LIFE TEST: 10,000 CYCLES .
4. OTHER GENERAL SPEC. TO REFER "USB TYPE C PLUG SERIES SPEC."
5. TO CONFORM TO SINGATRON HAZARDOUS SUBSTANCE FREE SPEC.
6. HALOGEN FREE PRODUCT IDENTIFICATION MARK ON PRODUCT: (C)
7. HALOGEN FREE PRODUCT IDENTIFICATION LABEL ON PACKAGING: (C)



E	GROUND SPRING	1	STAINLESS STEEL	NICKEL PLATING
D	LATCH	2	STAINLESS STEEL	NICKEL PLATING
C	TERMINAL	24	COPPER ALLOY	AL 2~10μm-NI 30μ ON CONTACT AREA AND BATT. SW ON SOLDER AREA ALL OVER NICKEL PLATING
B	HOUSING	2	HIGH TEMP. THERMOPLASTIC UL 94V-0	BLACK
A	SHELL	1	STAINLESS STEEL	NICKEL PLATING
NO	DESCRIPTION	QTY	MATERIAL	PLATING & COLOR

UNLESS OTHERWISE SPECIFIED TOLERANCES

DECIMALS: ANGLES: X :±2° X.X :±0.3 X.X.X :±1' X.XX :±0.2

TITLE: USB C TYPE PLUG

DWN: Ya-Wei PART NO. ZUP2Y01-C00610F

CHKD: Jim-Dang SCALE :1 UNIT: mm

APVD: Jim-Dang SIZE: A3 SHEET: 1 OF 1 REV: C

Singatron Enterprise Co., Ltd.
信晉企業股份有限公司

CUSTOMER COPY

