

REV.	EGN NO.	OR DESCRIPTION	REVISED	DATE
A	PRODUCT RELEASE		Longjiong	2017/7/13
B	ECN NO: C202007-C01		Ye Wei	2020/09/15

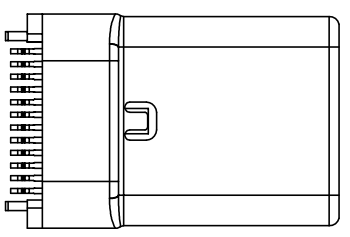

- SPECIFICATIONS:**
- ELECTRICAL CHARACTERISTICS:**
    - 1-1. RATING: 5A.
    - 1-2. CONTACT RESISTANCE: 40mΩ MAX.
    - 1-3. INSULATION RESISTANCE: 100 MEGOHMS MIN. BY 100V DC.
    - 1-4. DIELECTRIC WITHSTANDING VOLTAGE: 100V AC FOR 1 MINUTE.
  - MECHANICAL CHARACTERISTICS:**
    - 2-1. INSERTION FORCE : 0.5~2.0kgf.
    - 2-2. WITHDRAWAL FORCE : 0.8~2.0kgf.

3. LIFE TEST: 10,000 CYCLES.
4. OTHER GENERAL SPEC. TO REFER "USB C TYPE PLUG SERIES SPEC."
5. TO CONFORM TO SINGATRON HAZARDOUS SUBSTANCE FREE SPEC.
6. HALOGEN FREE PRODUCT IDENTIFICATION MARK ON PRODUCT:
7. HALOGEN FREE PRODUCT IDENTIFICATION LABEL ON PACKAGING:

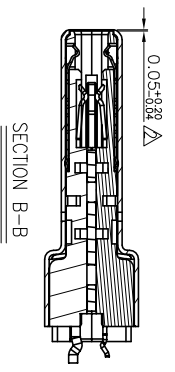
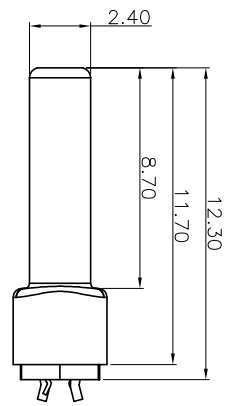
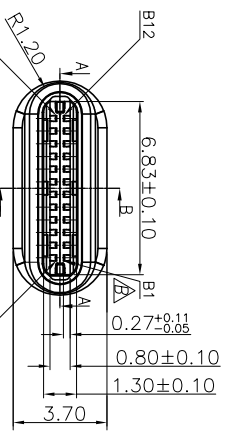
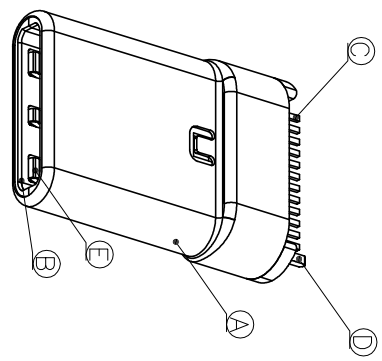
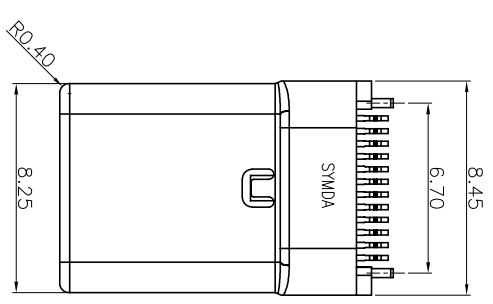
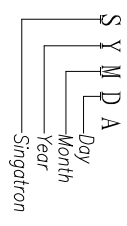

E	GROUND SPRING	1	STAINLESS STEEL	NICKEL PLATING
D	LATCH	2	STAINLESS STEEL	NICKEL PLATING
C	TERMINAL	24	COPPER ALLOY	AU 2~10μm-NI 30μ ON CONTACT AREA AND MAT. SW ON SOLDER AREA ALL OVER NICKEL PLATING
B	HOUSING	2	HIGH TEMP. THERMOPLASTIC UL 94V-0	BLACK
A	SHELL	1	STAINLESS STEEL	NICKEL PLATING
NO	DESCRIPTION	QTY	MATERIAL	PLATING & COLOR
UNLESS OTHERWISE SPECIFIED TOLERANCES				
Singatron Enterprise Co., Ltd. 信晉企業股份有限公司				
DECIMALS: ANGLES:				
X	:±0.5	X	:±2°	
X.X	:±0.3	X.X	:±1°	
X.XX	:±0.2			
TITLE: USB C TYPE PLUG				
DMN	Ym-Dmg	PART NO.	ZUP2Y01-C00710F	
CHKD	Jm-Dmg	SCALE	:1	UNIT: mm
APVD	Jm-Dmg	SIZE: A3	SHEET: 1 OF 1	REV: B
CUSTOMER COPY				

