

REV.	ECN NO OR DESCRIPTION	REVISED	DATE
A	PRODUCT RELEASE	WZJ_Wei	2017.02.20

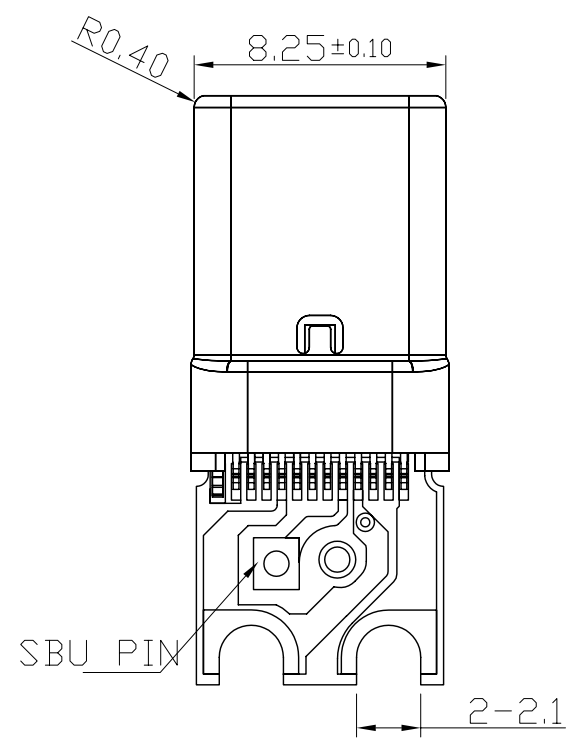

PIN ASSIGNMENTS:

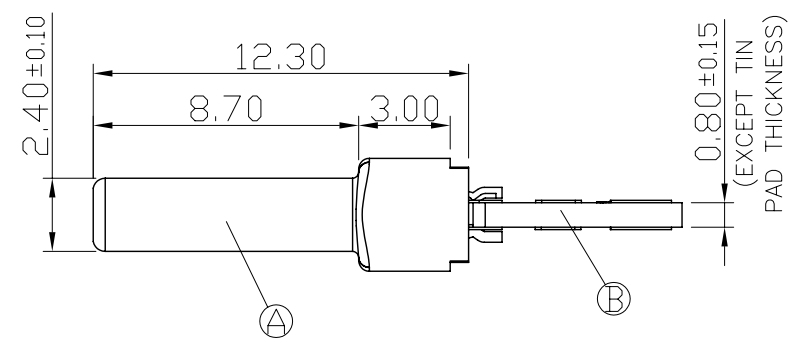
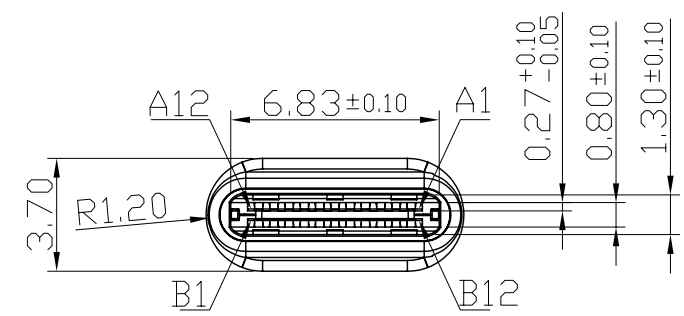
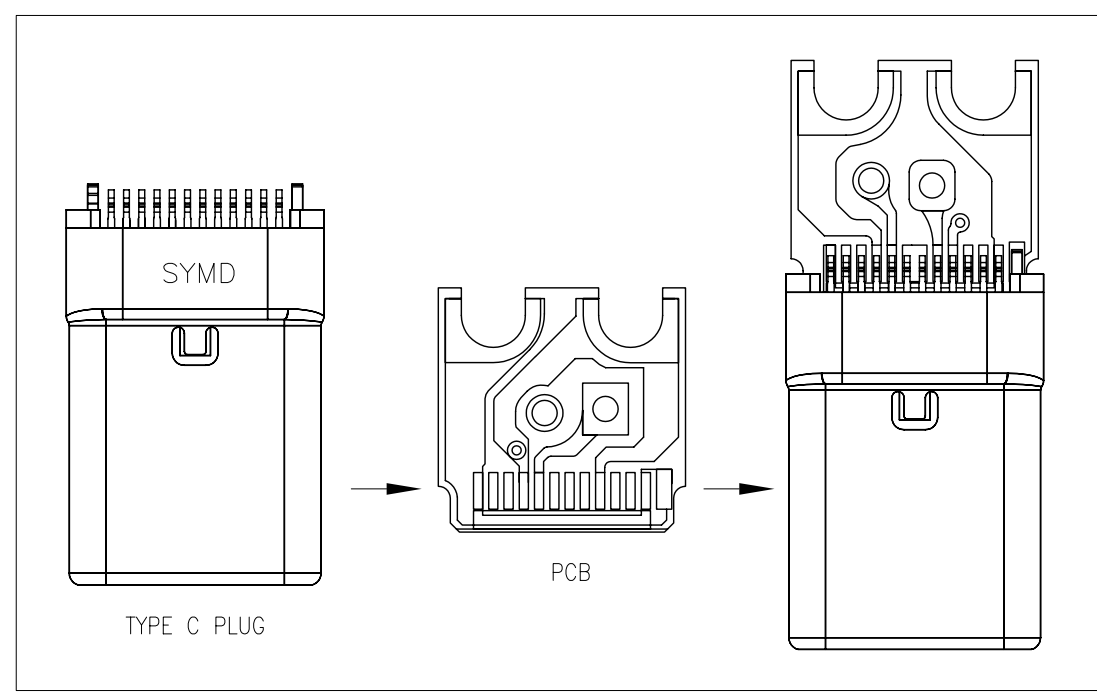
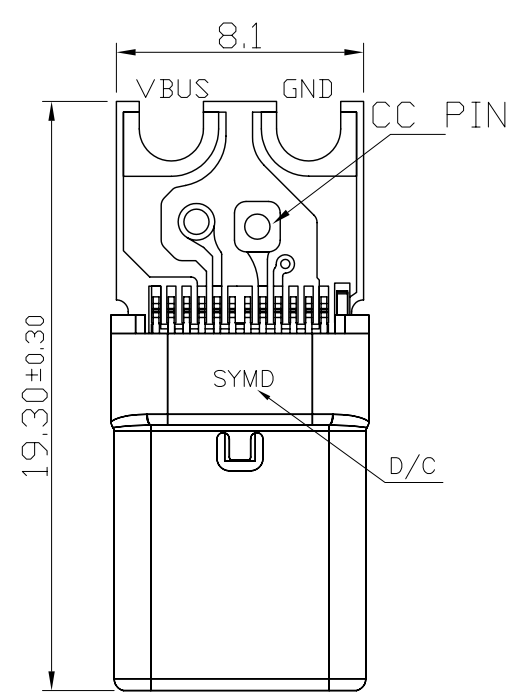
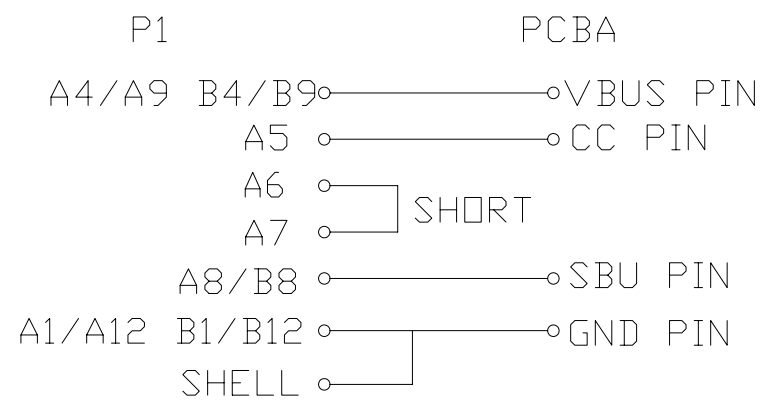

SPECIFICATIONS:

- ELECTRICAL CHARACTERISTICS:
 - RATING: 5A.
 - CONTACT RESISTANCE: 40mΩ MAX.
 - INSULATION RESISTANCE: 100 MΩ MIN. BY 100V DC .
 - DIELECTRIC WITHSTANDING VOLTAGE: 100V AC FOR 1 MINUTE.
- MECHANICAL CHARACTERISTICS:
 - INSERTION FORCE : 5~20N
 - WITHDRAWAL FORCE : 8N~20N(INITIAL), 6~20N(AFTER LIFE TEST).
- LIFE TEST: 10,000 CYCLES .
- OTHER GENERAL SPEC. TO REFER "USB TYPE C PLUG WITH PCB TYPE".
- TO CONFORM TO SINGATRON HAZARDOUS SUBSTANCE FREE SPEC.
- HALOGEN FREE PRODUCT IDENTIFICATION MARK ON PRODUCT:
- HALOGEN FREE PRODUCT IDENTIFICATION LABEL ON PACKAGING:

B	PCB	1	FR4	N/A
A	TYPE C PLUG	1	P/N: 2UP2Y01-C00110F	
NO	DESCRIPTION	QTY	MATERIAL	PLATING & COLOR
UNLESS OTHERWISE SPECIFIED TOLERANCES		Singatron Enterprise Co., Ltd. 信音企業股份有限公司		
DECIMALS: ANGLES:		TITLE: USB C TYPE PLUG + PCB		
X	±0.5 X ±2°	DWN	Zhijun-Wei 17/02/28	PART NO. 2UP2Y02-CSP111F
X.X	±0.3 X.X ±1°	CHKD	Zjz-Zhou 17/02/28	SCALE 5:1 UNIT: mm
X.XX	±0.2	APVD	Max-Mei 17/02/28	SIZE: A3 SHEET:1 OF 1 REV: A
CUSTOMER COPY				