

REV.	ECN NO.	OR DESCRIPTION	REVISED	DATE
A	PDR_T140103-1B		Harfen	2014.4.26
B	ECN NO.:S202211-R10		JAY	2022.11.22

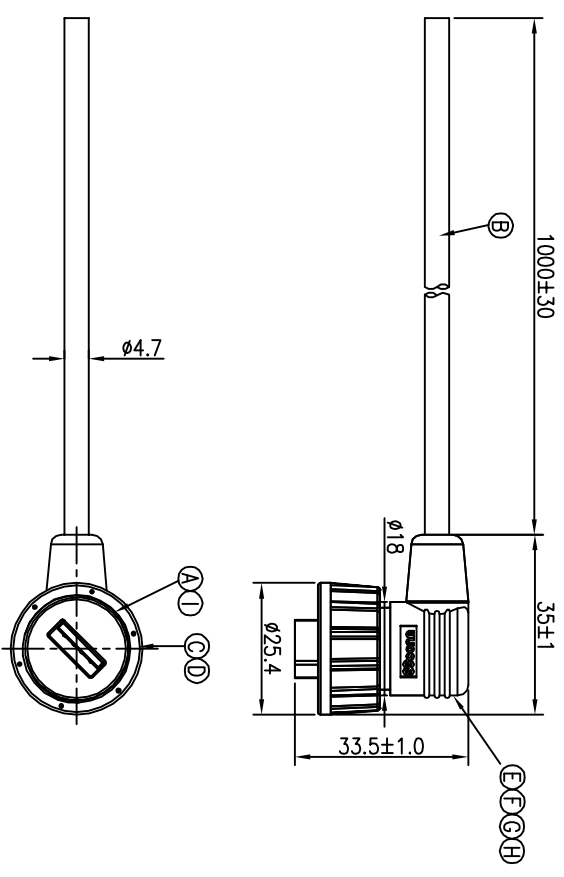

DRAIN	SHIELD
BLACK	4
GREEN	3
WHITE	2
RED	1

WIRE COLOR	CONN.
PIN OUT	
PIN4	

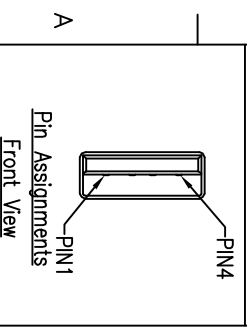

- NOTES:
- ELECTRICAL CHARACTERISTICS:
    - 1-1 CURRENT RATING: 1.0 AMPS.
    - 1-2 CONTACT RESISTANCE: 3 Ohm Max.
    - 1-3 INSULATION RESISTANCE: 1000 MOhm Min. at 500VDC.
    - 1-4 BREAKDOWN VOLTAGE: 500 VAC PER MINUTE.
  - ENVIRONMENTAL:
    - 2-1 OPERATING TEMPERATURE: -20°C TO +80°C.
    - 2-2 SEALING REQUIREMENTS: IP67.
  - FOR TECHNICAL DATA REFER TO YOUR LOCAL SINGATRON ELECTRONICS SALES OFFICE.
  - ALL DIMENSIONS ARE NOMINAL FOR REFERENCE ONLY UNLESS OTHERWISE STATED.
  - TO CONFORM TO SINGATRON HAZARDOUS SUBSTANCE FREE SPEC.
  - GREEN PRODUCT IDENTIFICATION LABEL ON PACKAGING:



I	BODY	1	PPE	BLACK
H	LIQUID GLUE	1	N/A	BLACK
G	TUBE	1	Ø1.0(125,300V)	BLACK
F	INNER MOLD	1	TPU	NATURAL
E	OVER MOLD	1	TPU	BLACK
D	GASKET	1	Silicone	BLACK
C	SCREW NUT	1	PC	BLACK
B	CABLE	1	USB2.0 28#*1P+24#*2C+A+DB,UV	BLACK
A	USB CONN.	1	USB 2.0 PLUG	N/A

UNLESS OTHERWISE SPECIFIED TOLERANCES

DECIMALS: ANGLES:

X :±0.5 X :±2  
X.X :±0.3 X.X :±1'  
X.XX :±0.2

Suzhou Singatron Auto Electronics CO.,LTD.  
苏州新航汽车电子有限公司

TITLE: USB 2.0 PLUG WITH CABLE(90°)

DWN: JAY PART NO.:ZUP3005-W05100H  
CHKD: MF SCALE 1:1 UNIT: mm  
APVD: JF SIZE: A3 SHEET: 1 OF 1 REV: B

CUSTOMER COPY