



REV	ECN No.	DATE	REMARK
A		2018.08.30	NEW RELEASE

SPECIFICATION

MATERIAL

See drawing

STANDARD DATA

Rating current: 5.0A

ELECTRICAL

Insulator resistance: 100Mohms Min.

Withstanding voltage: 100 VAC / minute

Contact resistance: 40mohms Max.

MECHANICAL

Mating force: 5~20N Max.

Unmating force : 6~20N Min.

Durability: 10,000 cycles Min.

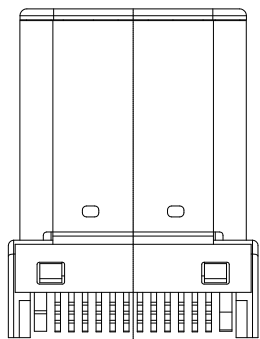
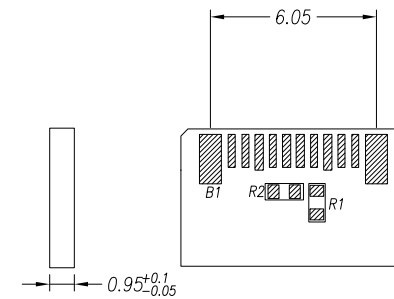
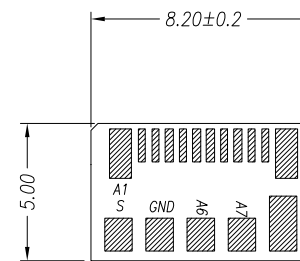
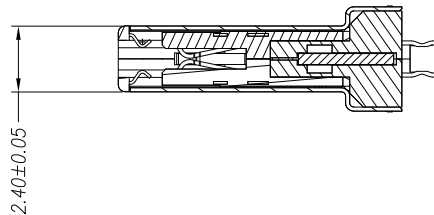
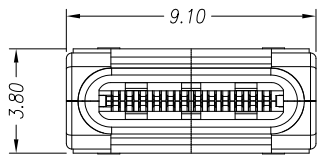
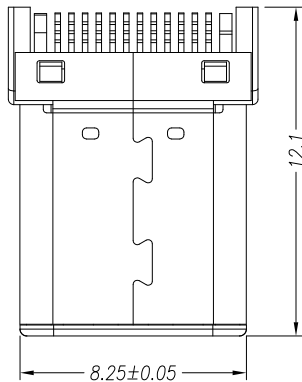

A12	A11	A10	A9	A8	A7	A6	A5	A4	A3	A2	A1
GND	RX2+	RX2-	Vbus	SBU1	D-	D+	CC	Vbus	TX1-	TX1+	GND
GND	TX2+	TX2-	Vbus	Vconn			SBU2	Vbus	RX1-	RX1+	GND
B1	B2	B3	B4	B5	B6	B7	B8	B9	B10	B11	B12

ITEM	PARTS NAME	Q'TY	MATERIAL ??	FINISH/REMARK
1	SHELL	1	SUS301	Ni:50U"
2	Molding HOUSING	2	LCP E130i	黑色
3	GND SPRING	2	SUS304	
4	Insert molding 12PIN	2	LCP E130i	黑色
5	CONTACT	24	C7025	Contact area:gold flash, Solder tails:tin 100u",Ni:50u"
6	LATCH	1	SUS301	Ni:30U"
7	SHELL COVER	1	SUS304	Ni:50U"

QUALITY SYMBOL	0	GENERAL TOLERANCES (UNLESS SPECIFIED)
	x.xxxxx	+ ---
	x.xxx	+ ---
	x.xx	+ 0.25
	x.x	+ 0.30
▲	ANGULAR	+ --°

Singatron Enterprise Co., Ltd.			
TITLE	USB 3.1 TYPE-C PLUG2.0		
DWN	2018/08/30	PART NO. 2UPSM01-321202-141R	
CHKD	2018/08/30	SCALE 1:1	UNIT: mm
APVD	2018/08/30	SIZE: A3	SHEET:1 OF 1 REV: A
CUSTOMER COPY			