

SPECIFICATION
MATERIAL

See drawing
STANDARD DATA
Rating current:3.0A
ELECTRICAL
Insulator resistance: 100Mohms MIN
Withstanding voltage: 100 VAC /minute
Contact resistance: 40mohms MAX
MECHANICAL
Mating force: 5~20N MAX
Unmating force: 6~20N MIN
Durability: 10,000 cycles min

REV	ECN No.	DATE	REMARK
A		2017.07.12	NEW RELEASE

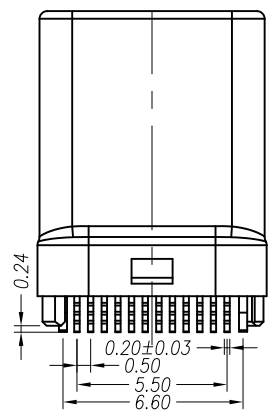
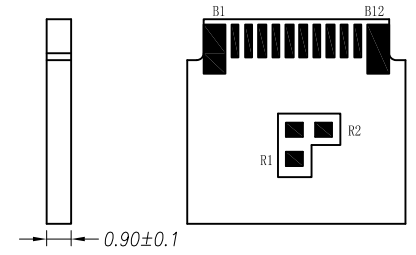
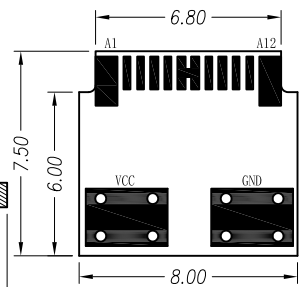
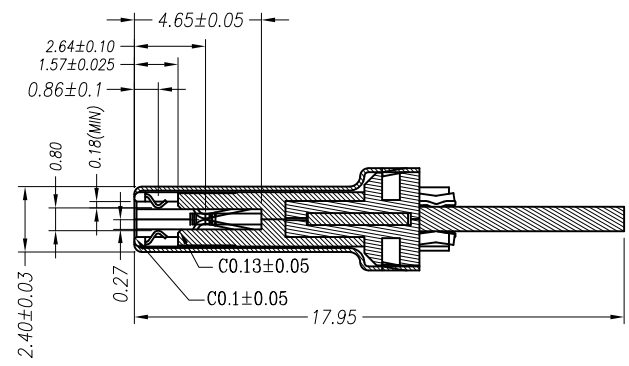
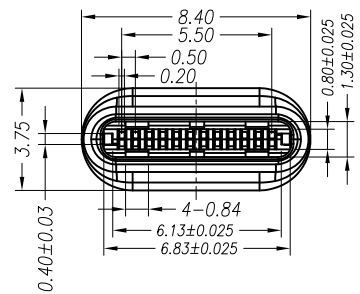

	Part Number	Color	Resistance
1	2UPSM04-431201-022T	Black	10KΩ
2	2UPSM04-431201-023T	White	22KΩ

ITEM	PARTS NAME	Q'TY	MATERIAL 材質	FINISH/REMARK
1	SHELL	1	SUS316L	Ni:50U"
2	Molding HOUSING	2	LCP E130i	黑色
3	GND SPRING	2	SUS304	
4	Insert molding 12PIN	2	LCP E130i	黑色
5	CONTACT	24	C7025	Contact area:gold flash, Solder tails:tin 100u".Ni:50u"
6	LATCH	1	SUS301	Ni-30U"

A12	A11	A10	A9	A8	A7	A6	A5	A4	A3	A2	A1
GND	RX2+	RX2-	Vbus	SBU1	D-	D+	CC	Vbus	TX1-	TX1+	GND
GND	TX2+	TX2-	Vbus	Vconn			SBU2	Vbus	RX1-	RX1+	GND
B1	B2	B3	B4	B5	B6	B7	B8	B9	B10	B11	B12

GENERAL TOLERANCES (UNLESS SPECIFIED)	
X.XXXXX	± ---
X.XXX	± ---
X.XX	± 0.25
X.X	± 0.30
ANGULAR	± ---

Singatron Enterprise Co., Ltd.			
TITLE	USB 3.1 TYPE-C PLUG(拉伸壳) 2个焊盘PCB		
DWN	David 2017/07/12	PART NO.	2UPSM04-431201-02xT
CHKD	David 2017/07/12	SCALE 1:1	UNIT: mm
APVD	David 2017/07/12	SIZE: A3	SHEET:1 OF 1 REV: A
CUSTOMER COPY			