

REV	ECN NO.	DESCRIPTION	DATE	APP'D
B/3	N/A	MODIFY TOLERANCE	03/21/17	Paul
B/4	N/A	Corrected mating height 1.45mm to 1.51mm	05/02/17	Paul
B/5	N/A	ADD 11,12 SPECIFICATION	08/22/17	Paul

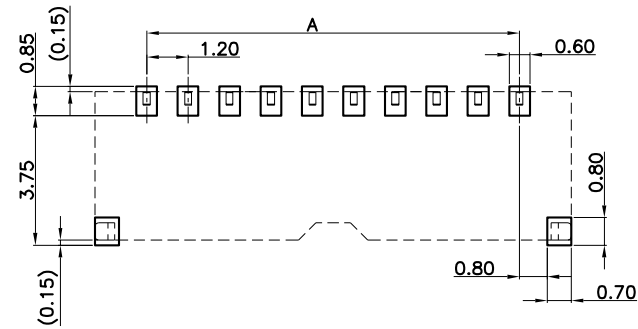

TOLERANCE: ±0.05
RECOMMENDED P.C.B. Layout
TOP VIEW

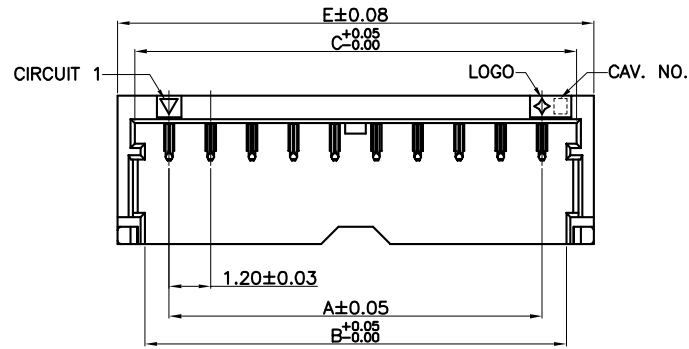
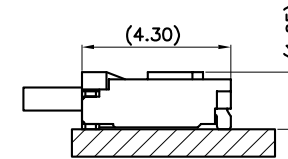
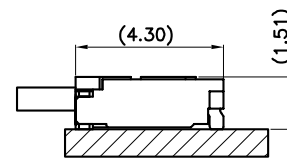
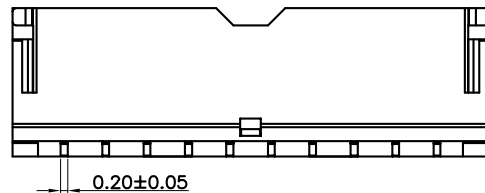
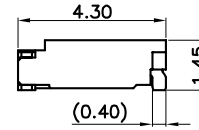

Mating Condition (REF.)
MATES WITH: 2WB1202HNO-NP
2WB1202HNO-NPB

Mating Condition (REF.)
MATES WITH: 2WB1202HNO-06A

PIN	DIM. (mm)				
	A	B	C	D	E
02	--	2.60	3.20	3.20	4.20
03	2.40	3.80	4.40	4.40	5.40
04	3.60	5.00	5.60	5.60	6.60
05	4.80	6.20	6.80	6.80	7.80
06	6.00	7.40	8.00	8.00	9.00
07	7.20	8.60	9.20	9.20	10.20
08	8.40	9.80	10.40	10.40	11.40
09	9.60	11.00	11.60	11.60	12.60
10	10.80	12.20	12.80	12.80	13.80
11	12.00	13.40	14.00	14.00	15.00
12	13.20	14.60	15.20	15.20	16.20

NOTES:

- MATERIAL:
INSULATION(HALOGEN FREE): LCP, UL94V-0 (BLACK)
CONTACT: COPPER ALLOY
SOLDER TAB: COPPER ALLOY, t=0.20mm / MATTE-TIN PLATED OVER NICKEL
- CONTACT FINISH: (VOID)--MATTE-TIN PLATED OVER NICKEL
GO--GOLD FLASH OVER NICKEL
G*--GOLD *u* OVER NICKEL
- MATES WITH: 2WB1202 SERIES HOUSING
- ORDERING CODE: 2WB1202WNV-NPSA-*NL-A



TOLERANCE
X.X ±0.25
X.XX ±0.15
ANGULA 3°
UNLESS OTHERWISE SPECIFIED

Singatron Enterprise Co., Ltd.				
TITLE	WIRE TO BOARD, PITCH 1.20mm, SMT TYPE, ASSEMBLY			
DWN	Bong Wang	PART NO.	2WB1202WNV-NPSA-*NL-A	
CHKD	Paul Chen	SCALE	1:1	UNIT: mm
APVD	Wayne Lai	SIZE: A3	SHEET 1 OF 4	REV: B/5
CUSTOMER COPY				

REV	ECN NO.	DESCRIPTION	DATE	APP'D
B/3	N/A	MODIFY TOLERANCE	03/21/17	Paul
B/4	N/A	Corrected mating height 1.45mm to 1.51mm	05/02/17	Paul
B/5	N/A	ADD 11,12 SPECIFICATION	08/22/17	Paul

02

03~05

06,08,10,12

07,09,11

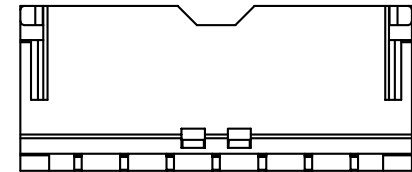
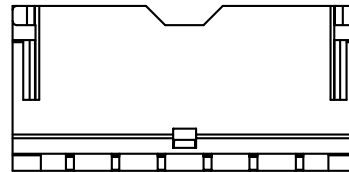
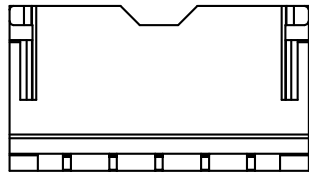
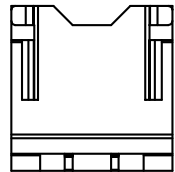
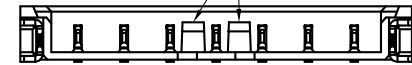
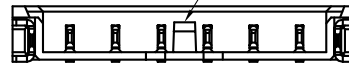
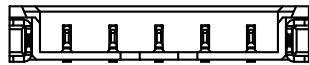
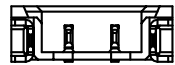
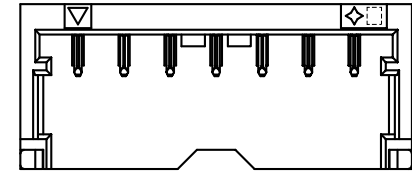
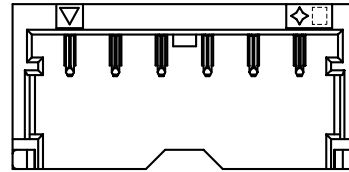
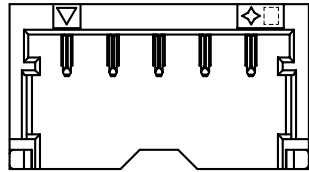
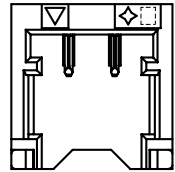

TOLERANCE
 X.X ±0.25
 X.XX ±0.15
 ANGULA 3°
 UNLESS OTHERWISE SPECIFIED

Singatron Enterprise Co., Ltd.				
TITLE	WIRE TO BOARD, PITCH 1.20mm, SMT TYPE, ASSEMBLY			
DWN	<i>Song Wang</i>	PART NO.	2WB1202WNV-NPSA-*--NL-A	
CHKD	<i>Paul Chen</i>	SCALE	1:1	UNIT: mm
APVD	<i>Wayne Lai</i>	SIZE	A3	SHEET 2 OF 4 REV: B/5
CUSTOMER COPY				

REV	ECN NO.	DESCRIPTION	DATE	APP'D
B/3	N/A	MODIFY TOLERANCE	03/21/17	Paul
B/4	N/A	Corrected mating height 1.45mm to 1.51mm	05/02/17	Paul
B/5	N/A	ADD 11,12 SPECIFICATION	08/22/17	Paul

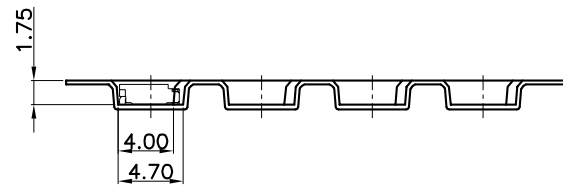
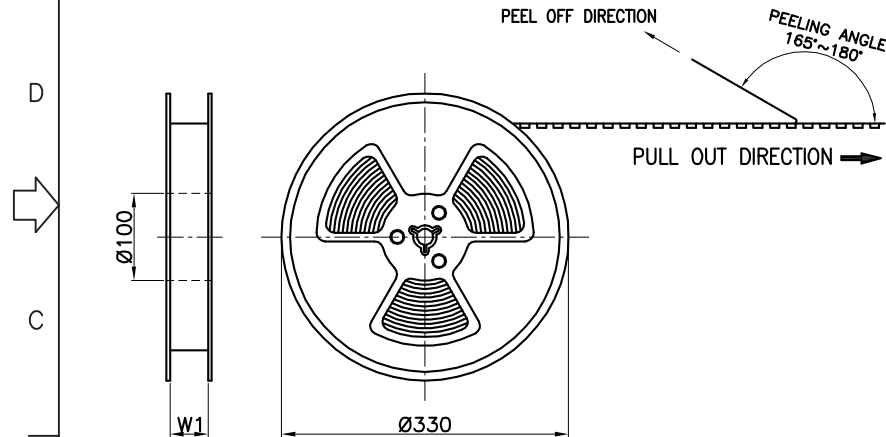
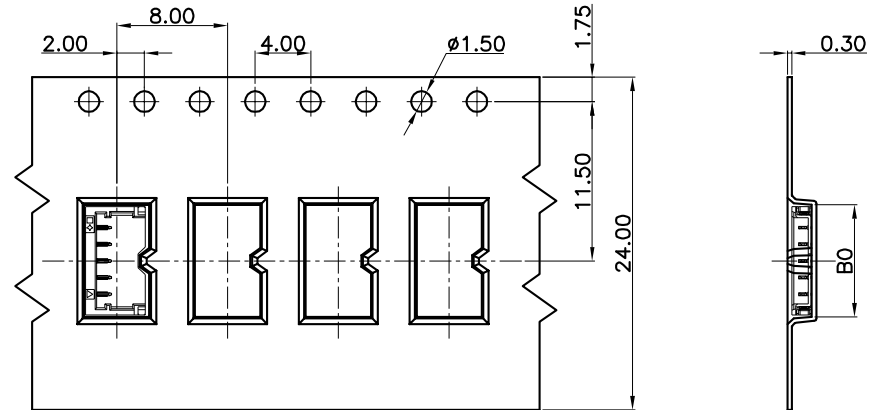
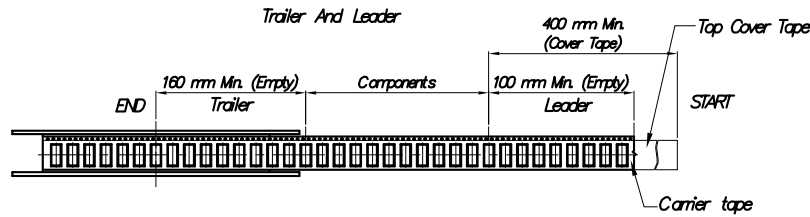

PIN	DIM.(mm)
	B0
02	4.50
03	5.70
04	6.90
05	8.10
06	9.30
07	10.50
08	11.70
09	12.90
10	14.10
11	15.30
12	16.50

- 10 SPROCKET HOLE PITCH CUMULATIVE TOLERANCE ± 0.20
- CARRIER CAMBER IS WITHIN 1 mm IN 250 mm
- THE TOTAL TEARING CONTROL RANGE OF TOP COVER TAPE IS 10~130g, REFERENCE SPEC: EIA-481-D
- PEELING SPEED: 300mm/MINUTES, REFERENCE SPEC: EIA-481-D
- MATERIAL: TRANSPARENT CONDUCTIVE POLYSTYRENE ALLOY.(UP-5000)
- ALL DIMENSIONS MEET EIA-481-D REQUIREMENTS
- THICKNESS : 0.30 ± 0.05 mm
- COMPONENT LOAD PER 13" REEL : 4500 PCS

TOLERANCE
 X.X ± 0.25
 X.XX ± 0.15
 ANGULA 3'
 UNLESS OTHERWISE SPECIFIED

Singatron Enterprise Co., Ltd.			
TITLE	WIRE TO BOARD, PITCH 1.20mm, SMT TYPE, ASSEMBLY		
DWN	Bong Wang	PART NO.	2WB1202WNV-NPSA-*~NL-A
CHKD	Paul Chen	SCALE	1:1 UNIT: mm
APVD	Wayne Lai	SIZE	A3 SHEET 3 OF 4 REV: B/5
CUSTOMER COPY			

REV	ECN NO.	DESCRIPTION	DATE	APP'D
B/3	N/A	MODIFY TOLERANCE	03/21/17	Paul
B/4	N/A	Corrected mating height 1.45mm to 1.51mm	05/02/17	Paul
B/5	N/A	ADD 11,12 SPECIFICATION	08/22/17	Paul

PCAKING MATERIAL	
PART NAME	DIM(mm)
REEL	∅300*(W+0.5)
CARTON	350*350*340

PCAKING CAPACITY			
PIN	PCS/RE	RE/BC	PCS/BC
02~12	4,500	10	45,000

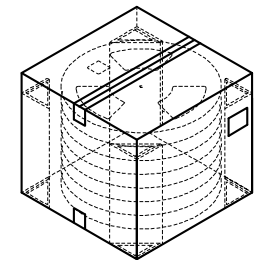
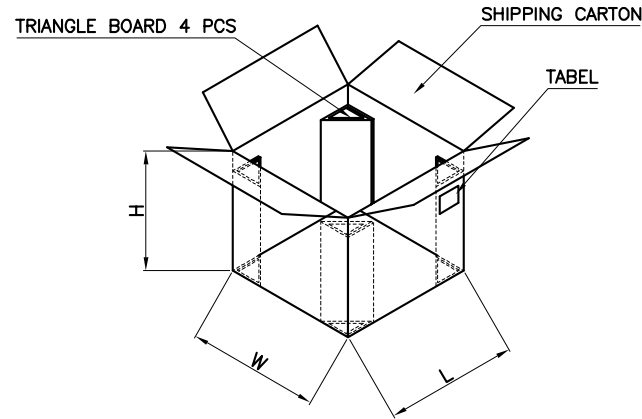
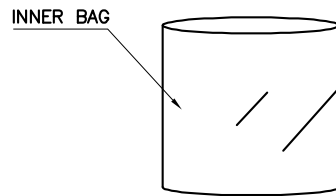
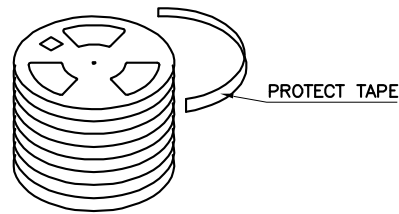
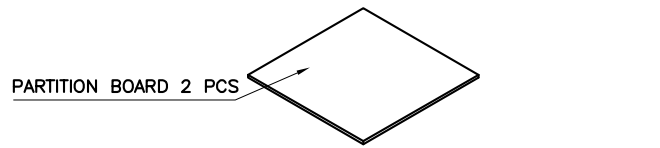

TOLERANCE
 X.X ±0.25
 X.XX ±0.15
 ANGULA 3'
 UNLESS OTHERWISE SPECIFIED

Singatron Enterprise Co., Ltd.				
TITLE	WIRE TO BOARD, PITCH 1.20mm, SMT TYPE, ASSEMBLY			
DWN	Bong Wang	PART NO. 2WB1202WNV-NPSA-*--NL-A		
CHKD	Paul Chen	SCALE 1:1	UNIT: mm	① ↗
APVD	Wayne Lai	SIZE: A3	SHEET 4 OF 4	REV: B/5
CUSTOMER COPY				